



TECH MANUAL
2024/25

elan™
Always Good Times

TABLE OF CONTENTS

NEWS 2024/25

BRAND	4
SAFETY FEATURES	6
BOOT BINDING COMPATIBILITY	7
ALMONTE	8
ATTACK LYT	8

TECHNICAL INFORMATION

ELAN TECHNOLOGIES	10
REFERENCE PARTS - RETAIL	12
REFERENCE PARTS - AAA-SERIES	13
ELAN BINDING LINE 2024/25	14
RENTAL	18
RENTAL TECHNOLOGY	18
TECHNICAL INFORMATION ESP 10.0, ESR 10.0	20
ELAN RENTAL LINE 2024/25	22
DEALER ONLINE SUPPORT	24
JUST ONE CLICK	25
PRODUCT PREPARATION	26
MOUNTING POSITIONS FOR MODELS 2024/25	28

ADJUSTMENT

CLASSIFY YOURSELF	32
RELEASE/RETENSION ADJUSTMENT TABLE	33
RENTAL-TEST AND INSPECTION PROCEDURES	35

MOUNTING BINDINGS & PLATES

WORKSHOP TOOLS AND AIDS	42
DRILL TEMPLATE SELECTION	43
DRILL TEMPLATE 92W & 92 FAT	48
DRILL TEMPLATE AMBITION	52
DRILL TEMPLATE 94W	56
DRILL TEMPLATE ATTACK DEMO	58
DRILL TEMPLATE BASES & PLATES	61
DRILL TEMPLATE RACEPLATE WCR	66
DRILL TEMPLATE RACEPLATE WCR SHORT / TEAM	68
DRILL TEMPLATE RACEPLATE 09	70
DRILL TEMPLATE FREEFLEX DEMO	72
DRILL TEMPLATE SP 2003 W	74
DRILL TEMPLATE SR 2003 W	76
DRILL TEMPLATE TOUR PT	78
FUSION X	82
SHIFT	84
JUNIOR SHIFT	86
ELAN BRAKE LINE 2024/25	89
BOOT SOLE TYPES - ISO STANDARDS	92
BOOT HANDLING AND TESTING	94
TROUBLESHOOTING (INCLUDING RENTAL)	99

DEALER SERVICE INFORMATION

ELAN CERTIFICATION REQUIREMENTS	102
ELAN DEALER INDEMNITY PROGRAM	104
INSTRUCTIONS OF USE	108
LIMITED WARRANTY AND LIMITATION OF LIABILITY	110
ELAN RISK MANAGEMENT	111
USE OF NON RECOMMENDED SETTINGS	113
POST ACCIDENT INSPECTION REPORT	114
SYSTEM PERFORMANCE REPORT	115
CHECKLIST	116

We build skis

At Elan, we don't just build skis, we build BETTER skis, and with over 75 years dedicated to handcrafting skis in the Alps, that's not just a statement, it's a promise. Earning praise year after year, Elan skis are not only validated by test results and design awards. They are also approved by top-level athletes, as well as thousands of skiers around the world, who trust Elan to provide equipment that produces exceptional experiences in the mountains, again and again. Thank you for supporting Elan and have a great and successful season.

The Elan Team

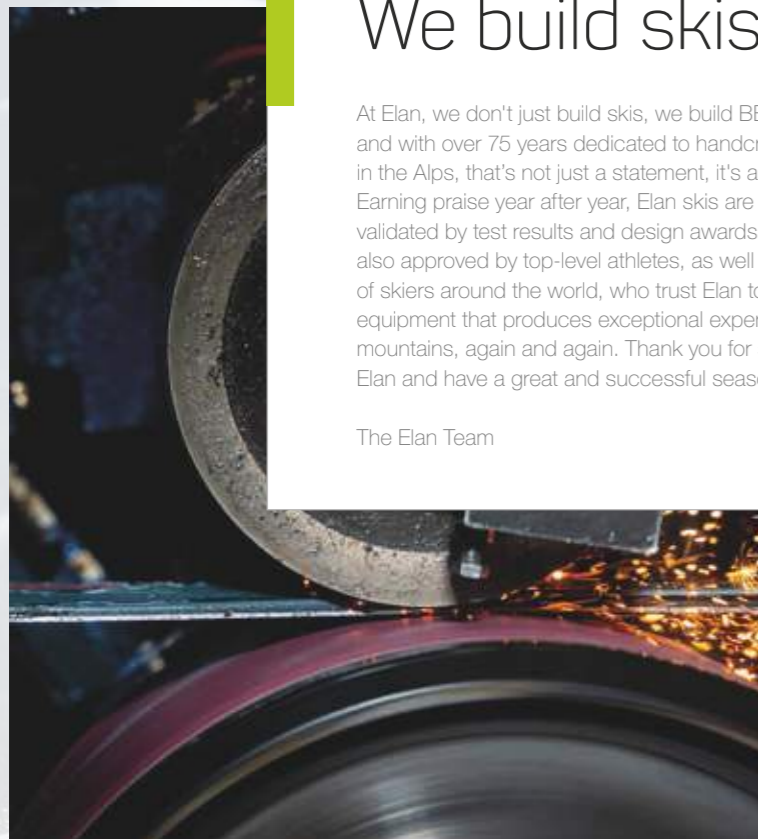

BRAND



100% handcrafted in the Alps for more than 75 years, ELAN is dedicated to innovation that makes the skiing experience better for everyone.

How?

What?

We build better skis. We live for the skiing lifestyle and challenge ourselves with new experiences.

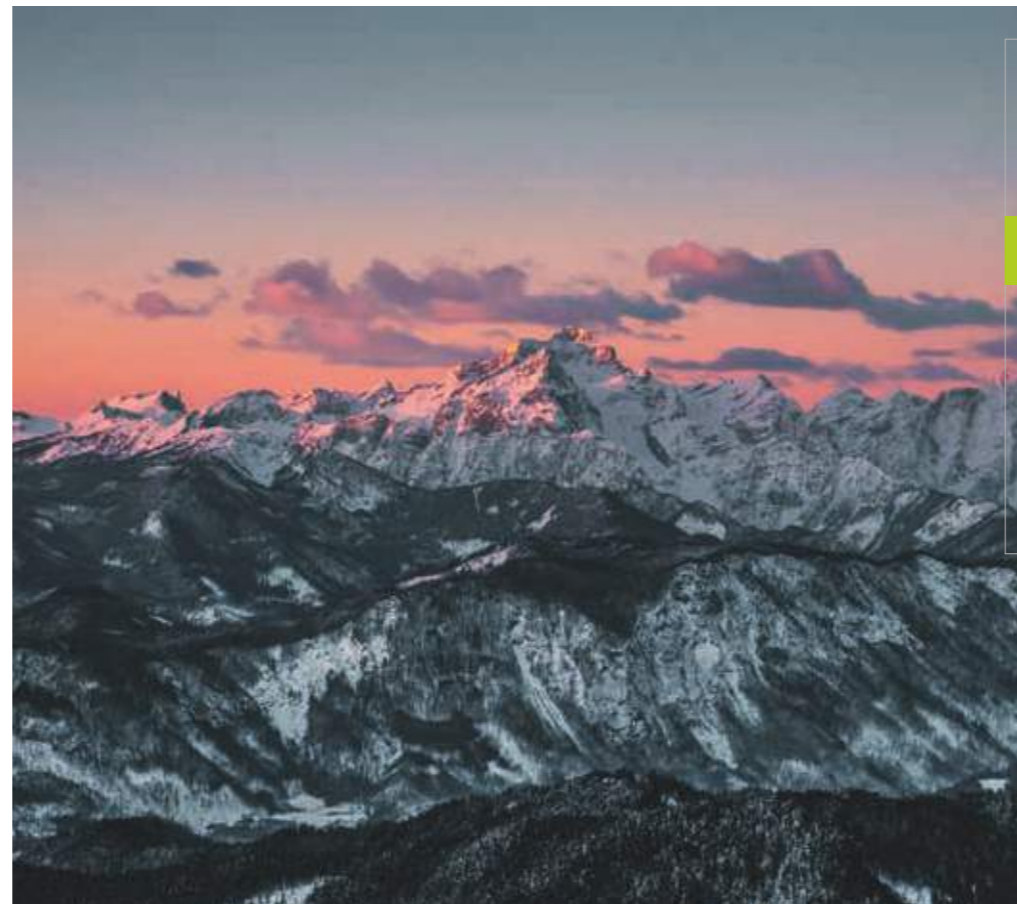

Why?

Whether you live in the city or the mountains, ELAN believes skiing should be experienced by everyone.

SAFETY FEATURES

ONLY PERFECTION PROVIDES SAFETY

A special dedication to Active Safety is a core value at ELAN. Continued advances in research and development, unparalleled performance and high-quality service guarantee a high-tech product renowned throughout the entire winter sports industry.

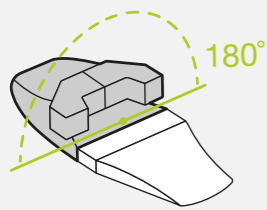

FULL DIAGONAL TOE – RX TOE

The RX Toe features more than improved aerodynamics. The TYROLIA Full Diagonal Release function delivers intelligent 180° release both horizontally and vertically.



FHR – FULL HEEL RELEASE

The TYROLIA Full Heel Release function delivers intelligent 180° release both horizontally and vertically ensuring maximum safety in forward and backward twisting fall situations. The FHR function can reduce ACL strain by more than 50 %*.

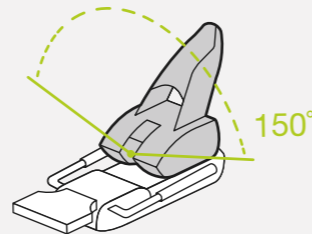

DIAGONAL® RX-HEEL – D-RX HEEL

With a 150° release range, the Diagonal Heel releases directly into the direction of the fall and reduces pressure on knees and ligaments in forward twisting fall situations.

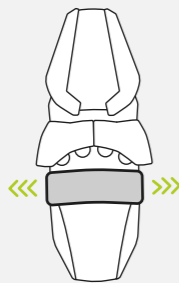

AFS - ANTI-FRICTION SLIDER

The TYROLIA Anti-Friction Slider (AFS) provides not only secure boot release but also rapid and exact boot re-centering. For better safety and reliability.



TRP -TOE SYSTEM

The TYROLIA Roller Pincer Toe System (TRP System) with its four rollers allows a 180° release and exact centering of the ski boot. The TRP system reduces the load on knees and ligaments and improves performance considerably.



ELAN is an official GripWalk partner. The entire ELAN binding line (except Racing) for adults and children is GripWalk compatible. The bindings can be used with Alpine ski boots (ISO 5355) plus GripWalk ski boots (ISO 23223).

BOOT BINDING COMPATIBILITY

In season 2024/25 all our ELAN bindings will have a specific marking on the toe (printed letter/symbol or in the mold of the AFD) to show the boot compatibility.



MARKING ON THE PRODUCT

A	A	A	A	CA	A	PIN

COMPATIBLE BOOT STANDARDS

Alpine Adult sole (ISO 5355-TYPE A)	Alpine Adult sole (ISO 5355-TYPE A)	Alpine Adult sole (ISO 5355 - TYPE A)	Alpine Adult sole (ISO 5355 - TYPE A)	Alpine Adult sole (ISO 5355 - TYPE A)	Alpine Adult sole (ISO 5355 - TYPE A)	
	Walk Adult sole (ISO 23223 -TYPE A)	Walk Adult sole (ISO 23223 -TYPE A)	Walk Adult sole (ISO 23223 -TYPE A)	Walk Adult sole (ISO 23223 -TYPE A)	Walk Adult sole (ISO 23223 -TYPE A)	Walk Adult sole (ISO 23223 -TYPE A)
				Alpine Children sole (ISO 5355 - TYPE C)		
				Walk Children sole (ISO 23223 - TYPE C)		
			Touring sole (ISO 9523)**		Touring sole (ISO 9523)**	Touring sole (ISO 9523)**
						Non compliant soles with tech. inserts

BINDING STANDARD

ISO 9462	ISO 9462	ISO 9462	ISO 9462	ISO 9462	ISO 9462	no standard
			ISO 13992		ISO 13992	

* Screwdriver icon indicates that the toe height needs to be adjusted by the technician.

** Although there is no Type A & C standard in ISO 9523 - MN bindings are marked with A to avoid possibly installing of a Type C Alpine or Walk boot in those bindings

ALMONTE

THE ULTIMATE PIN BINDING

Feel the absolute lightness on the ascent and high performance on the descent.

- Lightweight design (325 g/pc.)
- Simplified step-in
- Ergonomic toe lever
- Intuitive handling of hike & ski mode
- Automatic brake lock & an isolated mechanism to prevent icing
- Easy-to-use climbing aids (0°/6.5°/12°)
- Customizable performance spacer (1.5/2.5/3.5 mm)
- Sustainable materials –all plastic parts are made from renewable raw material
- Available in two colors



COLORS
■ ■

ATTACK LYT

LESS WEIGHT, MORE FUN

Our best freeski binding, now even lighter and more compact.

- 15 % Lighter toe
- Slimmer design
- Automatic toe height adjustment for Alpine & GripWalk boots
- Outstanding performance with precise re-centering
- Available in three colors



COLORS
■ ■ ■



TECHNICAL INFORMATION

TECHNICAL INFORMATION

ELAN TECHNOLOGIES

1. FUSION X

The Fusion X is Elan's high performance binding system. The single connection design enables a smoother, free flexing system between the ski and binding leading to easy turn initiation. The pyramid shaped construction is reinforced with aluminum for additional strength and creates direct edge-to-edge responsiveness and power transmission.

- 1 Pyramid shape
- 2 Perfect free-flex
- 3 Vibration absorber
- 4 Aluminum reinforcement

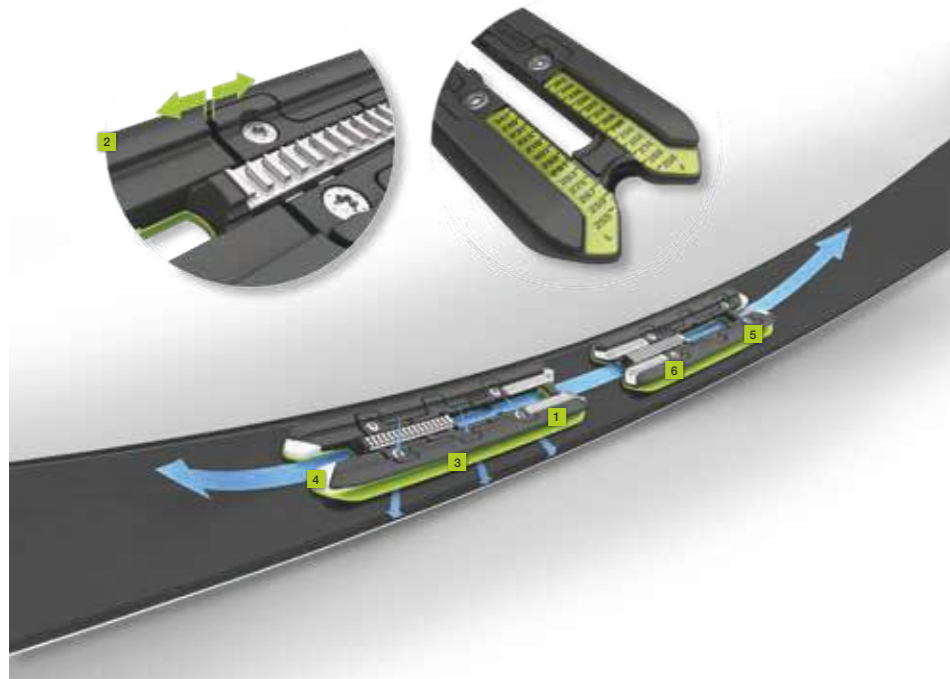

2. SHIFT

The Shift System is built with a lean profile comprised of lightweight materials, and designed to offer optimized performance.

The foundation of the Shift System is a plate-in-plate free flex design that allows the ski to bend along its length and vibration absorbers dampen chatter between the ski and the plate, improving the connection between the skier and snow.

Wide ABS platform creates optimal power transfer further increasing precision and edge hold.



LIGHTWEIGHT

- 1 THIN PROFILE
Reduced weight due to construction.

PERFORMANCE

- 2 "PLATE-IN-PLATE" FREEFLEX CONSTRUCTION
A new solution, two plates that move freely. This technology has free flex and great power transfer at the same time.
- 3 POWER TRANSFER PLATFORM
Delivers optimal power transfer further increasing precision and edge hold.
- 4 VIBRATION ABSORBERS
Improve comfort and provide a smooth ride in any situation.

EASY HANDLING

- 5 ENHANCE GLIDING
- 6 TOOL FREE, CLICK IN BINDINGS

3. JRS JUNIOR SHIFT

JRS Junior System is modern, lightweight design, enabling uniform flex of a ski, enabling easy learning and fast progression to a higher level. Incorporated locking rails make the system extremely light and deliver extraordinary flex. Size adjusting scales are deepened, therefore well protected, which makes JRS Junior System easy to adjust and long-lasting. Due to all attributes, JRS is a perfect match with U-Flex ski design, making skiing as easy as walking.



TECHNICAL INFORMATION

REFERENCE PARTS - RETAIL

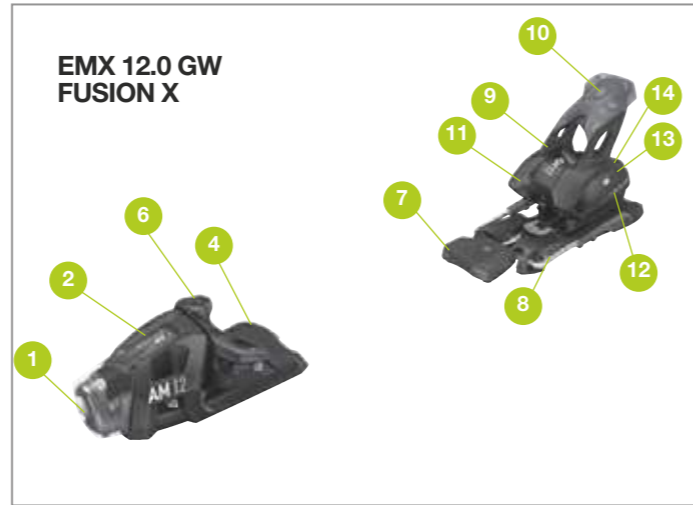
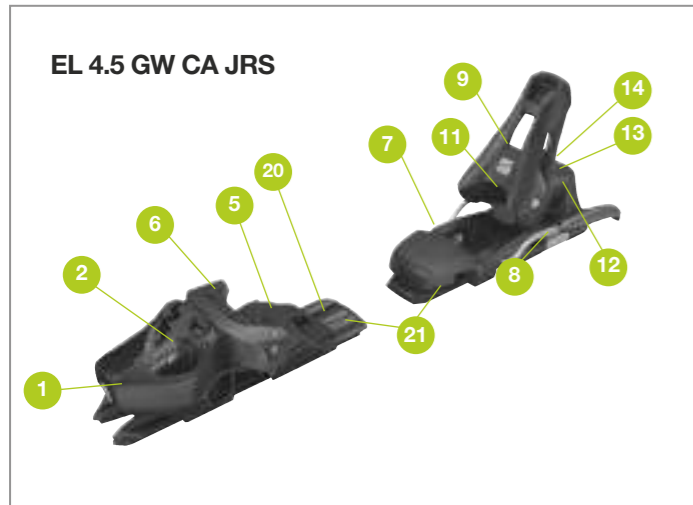
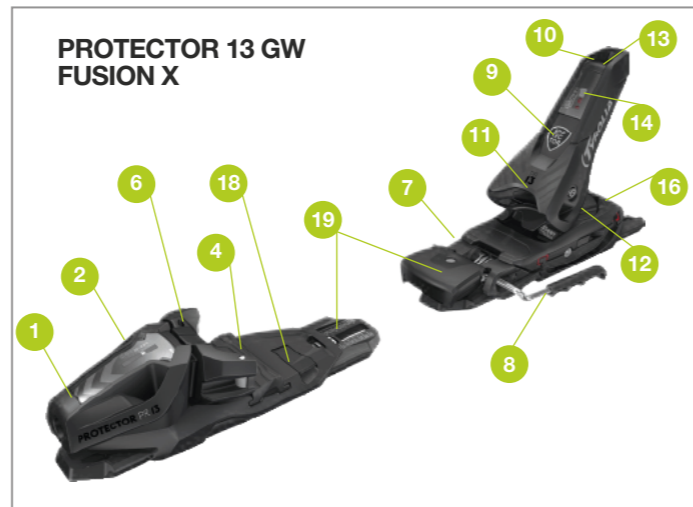
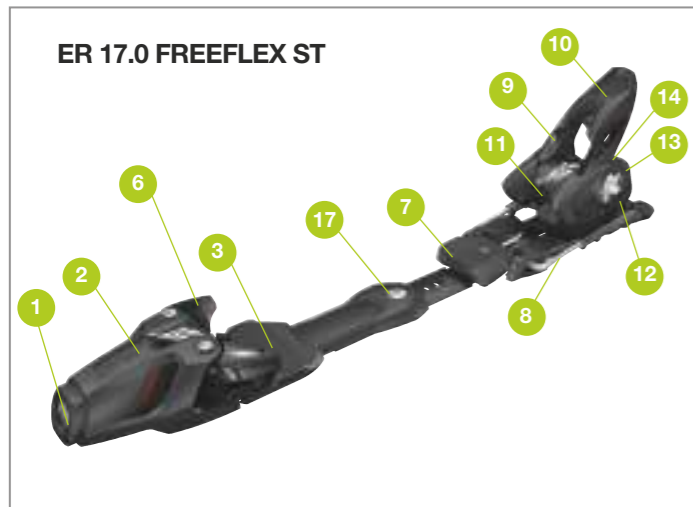

TOE PIECE

- 1 Adjustment screw
- 2 Visual indicator
- 3 Race AFD
- 4 GripWalk - AFS
- 5 GripWalk Junior - AFS
- 6 Wings

HEEL PIECE

- 7 Brake pedal
- 8 Brake arms
- 9 Heel lever
- 10 Heel cover
- 11 Sole lug
- 12 Heel housing
- 13 Adjustment screw
- 14 Visual indicator
- 15 Adjustment screw FHR
- 16 Visual indicator FHR

MID PARTS

- 17 Freeflex PRO
- 18 PR lever
- 19 PR scale
- 20 JRS/SLR lever
- 21 JRS/SLR scale

TECHNICAL INFORMATION

REFERENCE PARTS - AAA-SERIES

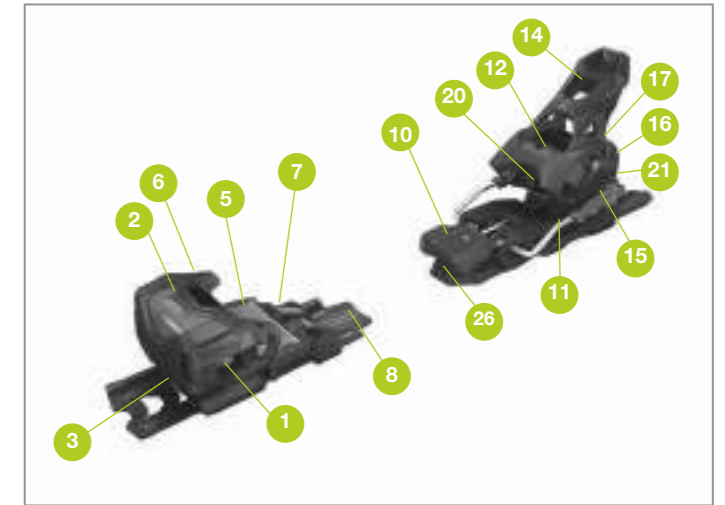
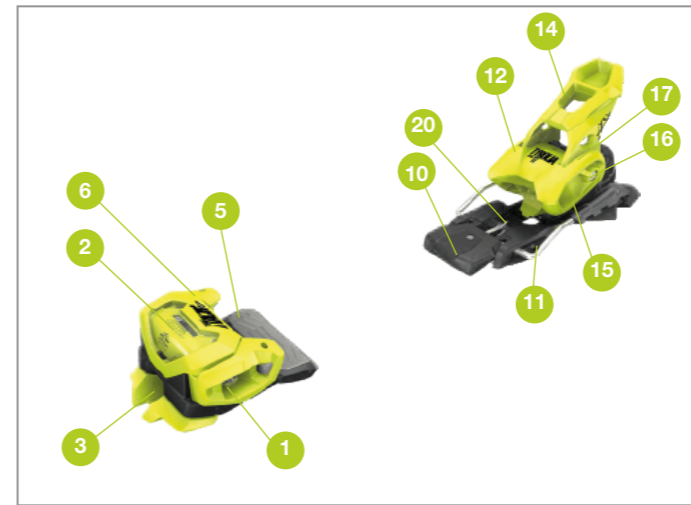
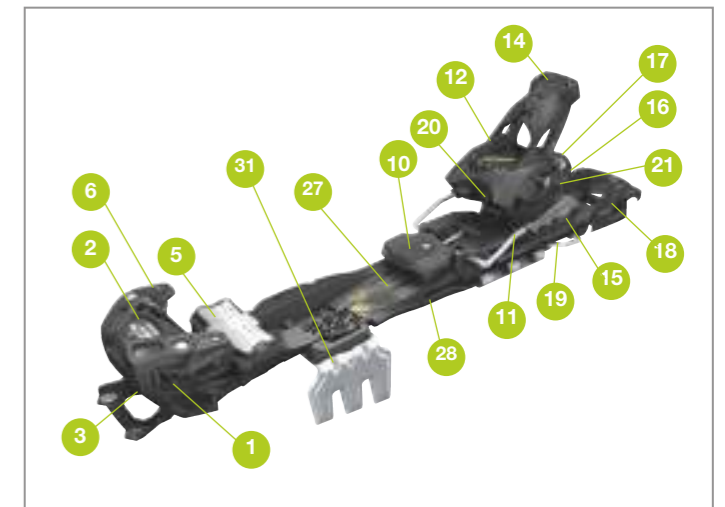
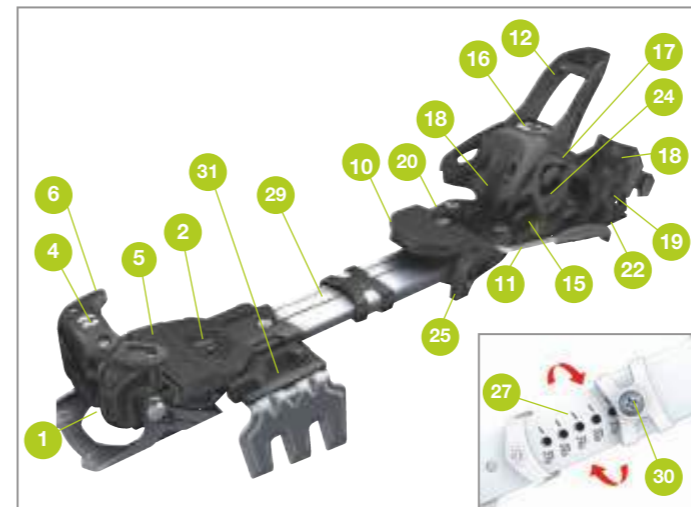

TOE PIECE

- 1 Adjustment screw
- 2 Visual indicator
- 3 Adjustment screw - AFS/AFD
- 4 Adjustment screw - sole height
- 5 AFS/AFD
- 6 Wings
- 7 Toe lever
- 8 Demo scale
- 9 Pins
- 10 Locking Lever

HEEL PIECE

- 11 Brake pedal
- 12 Brake arms
- 13 Heel lever
- 14 Heel lever
- 15 Heel lever
- 16 U-Pin
- 17 Heel cover

- 18 Heel housing
- 19 Adjustment screw
- 20 Visual indicator
- 21 Ascender look
- 22 Climbing aid
- 23 Sole lug
- 24 Heel adjustment lever
- 25 Heel base plate
- 26 Demo Track
- 27 Length adjustment screw
- 28 Dampener
- 29 Attack Demo scale

MID PARTS

- 30 Boot sole length scale
- 31 Walking platform
- 32 Telescopic tube
- 33 Length adjustment screw
- 34 Crampon

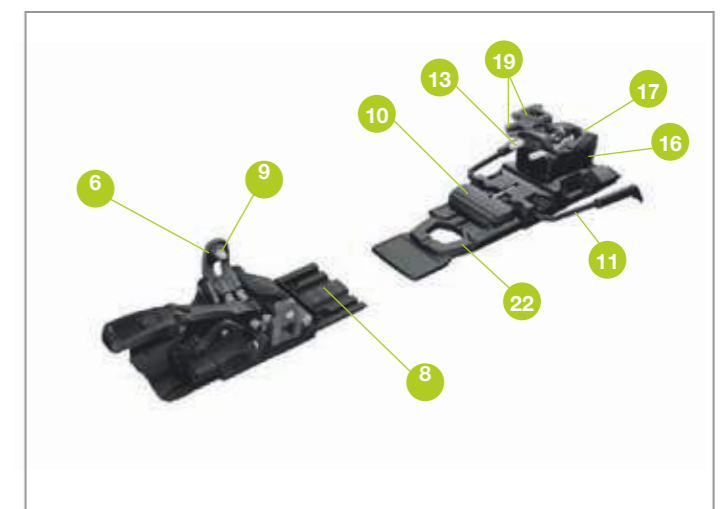

TECHNICAL INFORMATION

ELAN BINDING LINE 2024/25

Model	Ramp angle	Z - DIN	kg	lbs	Weight [g]	Jig	Feature	Toe					Heel					Boot sole				
								Type	System		AFD	Stand Height [mm]	Length Adj. Range [mm]	Type	System	Brake (tech.name)	Brake Code	Stand Height [mm]	Material Housing	Length Adj. Range [mm]	Length [mm]	DIN/ISO Standard
RACE																						
ER 18.0 X RD FREEFLEX ST Brake 85 [A]	3,5	8-18	from 79	from 175		92 W / 92 FAT	FREEFLEX Pro	Stream	---		AFD ST POM (X)	12,5	---	RACE PRO RD	Standard	PB ² Race Pro 16-85 [A]*	A	16,0	Steel / GFK	32	255 - 375	A
ER 17.0 FREEFLEX ST BRAKE 85 [A]	4,5	6 - 17	from 58	from 126		92 W / 92 FAT	FREEFLEX Pro	Stream	---		AFD ST Teflon	12,5	---	RACE PRO	Standard	PB ² Race Pro 17-85 [A]	A	17,0	Steel / GFK	32	255 - 375	A
ER 14.0 FREEFLEX GW BRAKE 85 [D]	7,0	4-14	from 42	from 92	2260	92 W / 92 FAT	FREEFLEX Pro	RX	Full Diagonal		ABS	14,0	---	NX	Standard	Power Brake ² LD 85 [D]	D	21,0	GFK	24	257 - 372	A
ER 11.0 FREEFLEX GW BRAKE 85 [D]	7,0	3-11	from 31	from 67	2260	92 W / 92 FAT	FREEFLEX Pro	RX	Full Diagonal		ABS	14,0	---	NX	Standard	Power Brake ² LD 85 [D]	D	21,0	GFK	24	257 - 372	A
ER 11.0 GW BRAKE 85 [D]	3,5	3-11	from 31	from 67	1920	92 W / 92 FAT	---	RX	Full Diagonal		ABS	17,5	---	Race Lite	Standard	Power Brake ² LD 85 [D]	D	21,0	GFK	24		A
ER 14.0 GW FREEFLEX DEMO BRAKE 85 [D]	1,5	4-14	from 42	from 92	2650	FREEFLEX DEMO	FREEFLEX DEMO	RX	Full Diagonal		AFS GW	19,5	64	NX	Rental	Power Brake ² LD 85 [D]	D	21,0	GFK	60	263-386	A/GW A
FUSION X																						
PROTECTOR 13 GW FUSION X Brake 85 [P]	5,5	4 - 13	from 42	from 92	2370	/	Powerrail	RX	Full Diagonal		AFS_GW	28	60	HR	FHR	Protector Brake PR 85 [P]	P	33,5	GFK	60		A/GW A
PROTECTOR 11 GW FUSION X Brake 85 [P]	5,5	3 - 11	from 31	from 67	2320	/	Powerrail	TX BTR	Full Diagonal		AFS_GW	28	60	HR	FHR	Protector Brake PR 85 [P]	P	33,5	GFK	60		A/GW A
EMX 14.0 GW Fusion X BRAKE 85 [F]	5,5	4-14	from 42	from 92	2000	/	FusionX	AM	Full Diagonal		AFS_GW	28	60	NX FR	Standard	Powerrail Brake ² LD 85 [F]	F	33,5	GFK	60		A/GW A
EMX 12.0 GW Fusion X BRAKE 85 [F]	5,5	3,5-12	from 36	from 79	2000	/	FusionX	AM	Full Diagonal		AFS_GW	28	60	NX FR	Standard	Powerrail Brake ² LD 85 [F]	F	33,5	GFK	60		A/GW A
EMX 11.0 GW Fusion X BRAKE 85 [F]	5,5	3-11	from 31	from 67	1980	/	FusionX	AM	Full Diagonal		AFS_GW	28	60	NX FR	Standard	Powerrail Brake ² LD 95 [F]	F	33,5	GFK	60		A/GW A
EM 11.0 GW Fusion X BRAKE 85 [G]	3,0	3-11	from 31	from 67	1840	/	FusionX	AM	Full Diagonal		AFS_GW	28	60	SXG	Standard	Powerrail Brake SL 85 [G]	G	31	GFK	60		A/GW A
SET																						
EL 10.0 GW Brake 78 [J]	9,5	3-10	from 31	from 67	1650	92 W/92 FAT		SX	Full Diagonal		AFS_GW	11,5		SXG	Standard	W/O Brake [J]	J	21	GFK			A/GW A
AAA-SERIES																						
ALMONTE 12 PT W/O Brake [M]	-	5 - 12	from 49	from 108	325	TOUR PT		TOUR	None		PT			TOUR		Brake platform TOUR - W/O Brake [M]	M					PIN*
ALMONTE 10 PT W/O Brake [M]	-	4 - 10	from 42	from 92	325	TOUR PT		TOUR	None		PT			TOUR		Brake platform TOUR - W/O Brake [M]	M					PIN*
ALMONTE 10 PT DEMO W/O Brake [M]	-	4 - 10	from 42	from 92	420	TOUR PT		TOUR	None		PT			TOUR		Brake platform TOUR - W/O Brake [M]	M					PIN*
ATTACK 17 MN W/O Brake [A]	2 - 7	6 - 17	from 58	from 126	970	92 W / 92 FAT	Wide Track	FR PRO3	None		AFS metal MN	17 - 22		RACE PRO FR	Standard	W/O Brake [A]	A	24	Steel / GFK	32		PIN*
ATTACK 14 MN W/O Brake [A]	2 - 7	4 - 14	from 42	from 92	960	92 W / 92 FAT	Wide Track	FR PRO3	None		AFS metal MN	17 - 22		NX FR	Standard	W/O Brake [A]	A	24	GFK	32		PIN*
ATTACK LYT 11 GW W/O Brake [A]	4,0	3 - 11	from 31	from 67	905*	92 W / 92 FAT	Wide Track	FR LYT	None		AFS GW	13		SX FR	Standard	W/O Brake [A]	A	17	GFK	32 (-8/+24)		PIN*
ATTACK 14 MN DEMO W/O Brake [F]	3 - 7	4 - 14	from 42	from 92	1245*	Attack Demo	ATTACK DEMO	FR PRO3	None		AFS metal MN	25 - 29	60	NX FR	Standard	W/O Brake [F]	F	32	GFK	60	259-382	PIN*
ATTACK LYT 11 GW DEMO W/O Brake [F]	4,0	3 - 11	from 31	from 67	1160*	Attack Demo	ATTACK DEMO	FR LYT	None		AFS GW	28		SX FR	Standard	W/O Brake [F]	F	32	GFK	60	259-382	PIN*
AMBITION 12 MN W/O Brake [C]	1 (*5)	4 - 12	from 36	from 79	955*	Ambition	Telescopic Tube	AT	None		AFS	37		AT	Standard	W/O Brake [C]	C	38 (*42)	GFK	14	260-350	PIN*

A: Alpine Adults,
A/C: Alpine Adults and Alpine Children,
A/GW A: Alpine Adults and GripWalk Adults,
A/C/GW A/GW C: Alpine Adults, Alpine Children, GripWalk Adults and GripWalk Children,
A/GW A/T: Alpine Adults, Gripwalk Adults and Touring
PIN: For all Ski boots with tech inserts

Model	Ramp angle	Z - DIN	kg	lbs	Weight [g]	Jig	Feature	Toe					Heel						Boot Sole			
								Type	System	AFD	Stand Height [mm]	Length Adj. Range [mm]	Type	System	Brake (tech.name)	Brake Code	Stand Height [mm]	Material Housing	Length Adj. Range [mm]	Length [mm]	DIN/ISO Standard	
SHIFT (SLR)																						
PROTECTOR SHIFT 11 GW Brake 80 [N]	2,0	3 - 11	from 31	from 67	975		SLR	TX BTR	Full Diagonal		AFS GW	26	60	HR Lite	FHR	Protector Brake SLR 80 [N]	N	28	GFK	60		A, GWA
PROTECTOR SHIFT 11 GW Brake 90 [N]	2,0	3 - 11	from 31	from 67	975		SLR	TX BTR	Full Diagonal		AFS GW	26	60	HR Lite	FHR	Protector Brake SLR 90 [N]	N	28	GFK	60		A, GWA
PROTECTOR SHIFT 10 GW Brake 80 [N]	2,0	3 - 10	from 31	from 67	975		SLR	TX BTR	Full Diagonal		AFS GW	26	60	HR Lite	FHR	Protector Brake SLR 80 [N]	N	28	GFK	60		A, GWA
PROTECTOR SHIFT 10 GW Brake 90 [N]	2,0	3 - 10	from 31	from 67	975		SLR	TX BTR	Full Diagonal		AFS GW	26	60	HR Lite	FHR	Protector Brake SLR 90 [N]	N	28	GFK	60		A, GWA
ELX 11.0 GW SHIFT Brake 78 [H]	2,0	3 - 11	from 31	from 67	900		SLR	RX	Full Diagonal		AFS GW	26	40	NX	Standard	SL Brake LR 78 [H]	H	28	GFK	60		A, GWA
ELX 11.0 GW SHIFT Brake 85 [H]	2,0	3 - 11	from 31	from 67	900		SLR	RX	Full Diagonal		AFS GW	26	40	NX	Standard	SL Brake LR 85 [H]	H	28	GFK	60		A, GWA
ELW 11.0 GW SHIFT Brake 85 [H]	2,0	3 - 11	from 31	from 67	900		SLR	RX	Full Diagonal		AFS GW	26	40	NX	Standard	SL Brake LR 85 [H]	H	28	GFK	60		A, GWA
ELW 11.0 GW SHIFT Brake 78 [H]	2,0	3 - 11	from 31	from 67	900		SLR	RX	Full Diagonal		AFS GW	26	40	NX	Standard	SL Brake LR 78 [H]	H	28	GFK	60		A, GWA
ELS 11.0 GW SHIFT Brake 85 [H]	2,0	3 - 11	from 31	from 67	820		SLR	RX	Full Diagonal		AFS GW	26	40	SXG	Standard	SL Brake LR 85 [H]	H	28	GFK	60		A, GWA
EL 10.0 GW SHIFT Brake 85 [H]	2,0	3 - 10	from 31	from 67	815		SLR	TX BTR	Full Diagonal		AFS GW	26	60	SXG	Standard	SL Brake LR 85 [H]	H	28	GFK	60		A, GWA
EL 10.0 GW SHIFT Brake 90 [H]	2,0	3 - 10	from 31	from 67	815		SLR	TX BTR	Full Diagonal		AFS GW	26	60	SXG	Standard	SL Brake LR 90 [H]	H	28	GFK	60		A, GWA
EL 9.0 GW SHIFT Brake 85 [H]	2,0	2,5 - 9	from 26	from 57	710		SLR	SX LITE	Full Diagonal		AFS GW	26	60	SXL	Standard	SL Brake LR 85 [H]	H	28	GFK	60		A, GWA
ELW 9.0 GW SHIFT Brake 85 [H]	2,0	2,5 - 9	from 26	from 57	710		SLR	SX LITE	Full Diagonal		AFS GW	26	60	SXL	Standard	SL Brake LR 85 [H]	H	28	GFK	60		A, GWA
EL 7.5 GW CA JRS Brake 78 [H]	1,5	2 - 7,5	22 - 84	48 - 187	610		JRS	SX Junior	Full Diagonal		AFS GW AC	25,5	48	SX Youth	Standard	SL Brake LR 78 [H]	H	27	GFK	48		A, C, GW A, GW C
EL 7.5 GW CA JRS Brake 90 [H]	1,5	2 - 7,5	22 - 84	48 - 187	610		JRS	SX Junior	Full Diagonal		AFS GW AC	25,5	48	SX Youth	Standard	SL Brake LR 90 [H]	H	27	GFK	48		A, C, GW A, GW C
EL 4.5 GW CA JRS Brake 80 [I]	1,5	0,75 - 4,5	10 - 48	22 - 105	575		JRS	SX Kid	Full Diagonal		AFS GW AC	25,5	48	SX Youth	Standard	SX Kid Brake SLR/JRS EASY 80 [I]	I	27	GFK	48		A, C, GW A, GW C
JUNIOR SET																						
EL 7.5 GW CA BRAKE 78 [J]	7,5	2-7,5	22-84	48 - 187	1410	92 W / 92 FAT	---	SX Jr	Full Diagonal		AFS GW CA	13,5	-	SX Youth	Standard	SL Brake 78 [J]	J	21,0	GFK	32		A/C/GW A/ GW C
EL 4.5 GW CA BRAKE 80 [K]	1,5	0,75-4,5	10-48	22 - 105	1220	94 W	---	SX Kid	Full Diagonal		AFS GW CA	13,5	-	SX Youth	Standard	SX Kid Brake 80 [K]	K	15,0	GFK	44		A/C/GW A/ GW C

A: Alpine Adults,
A/C: Alpine Adults and Alpine Children,
A/GW A: Alpine Adults and GripWalk Adults,
A/C/GW A/GW C: Alpine Adults, Alpine Children, GripWalk Adults and GripWalk Children,
A/GW A/T: Alpine Adults, Gripwalk Adults and Touring

TECHNICAL INFORMATION RENTAL

ON-SNOW DURABILITY AND EFFICIENCY IN THE RENTAL SHOP

Special features make the ELAN Rental bindings extremely long lasting and especially durable, and easier to handle, which makes them ideally suited for long-term use in the rental environment.

REFERENCE CHART - RENTAL

TOE PIECE

- 1 Adjustment screw
- 2 Visual indicator
- 3 AFS GW
- 4 Colored base plate (BYS)
- 5 One Touch lever
- 6 Base plate
- 7 Bar code area
- 8 Single code scale
- 9 Wings

HEEL PIECE

- 10 Brake pedal
- 11 Brake arms
- 12 Heel lever
- 13 Heel cover
- 14 Sole lug
- 15 Visual indicator
- 16 Heel housing
- 17 Adjustment screw
- 18 Single code scale
- 19 One touch lever

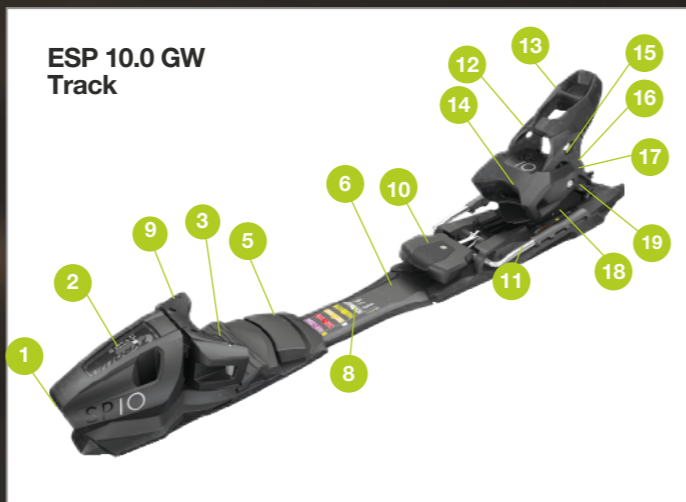

TECHNICAL INFORMATION RENTAL TECHNOLOGY

GripWalk COMPATIBILITY

The complete ELAN Rental binding range is GripWalk compatible. All bindings can be used with Alpine and GripWalk ski boots.

ELAN ONE-TOUCH-SYSTEM

The innovative One-Touch-System used for the ELAN Rental bindings ensures the simplest possible operation and length adjustment of toes and heels. Because – especially in the Rental sector – time is also money!

ELAN SYMPRO SYSTEM

The ELAN SYMPRO (SP) bindings are for any rental ski without integrated system. The length of the toe and heel can be adjusted with only a few easy steps for fast on-hill adjustment.

ELAN SYMRENT SYSTEM

The ELAN SYMRENT (SR) bindings are ideal for mounting on any rental ski. The mobile heel can be adjusted simply and very quickly to almost any size of a boot.

ELAN RENT HEEL AND TX TOE

The ELAN Rent heel features improved ergonomics, resistance and better protection against abrasion plus an optimized scale window – thus combining visual quality with safety and stability. Most of the Rental binding models are equipped with the TX toe with improved kinematics and the proven Rent One-Touch-System, optimized and much appreciated for rental purposes.

ELAN Single Code

The ELAN Single Code guarantees that rental agreements are processed in record time. There is only one unit of size in the form of clearly color-coded letters. This enables, toe, heel and boot to be adjusted very quickly.

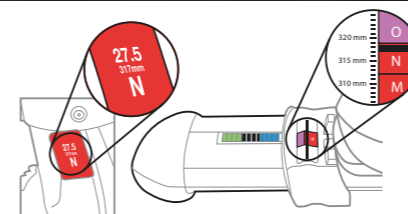

Determine

If the boot is already color-coded you can use the single code – if not, measure the boot with the measuring tool to determine the single code. enables, toe, heel and boot to be adjusted very quickly.

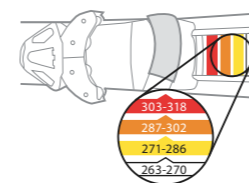

Adjust

Adjust the toe to the desired single code position (color-coded area), which is shown on the boot (N/red).

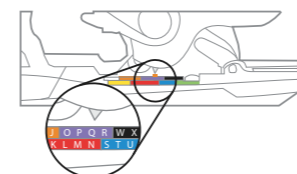

Ready

Set the heel to the desired single code position (letter), which is shown on the boot as well (N/red). The system is extremely accurate so no further checks are needed.

TECHNICAL INFORMATION

ESP 10.0, ESR 10.0

Performance, for a rental binding, is not only what happens on the hill. A key measure of a product's quality is the ease with which a system can be adjusted and maintained throughout the course of many seasons.

THE SHOP FRIENDLY RENTAL DESIGN FEATURES:

- Easy mounting: This means fewer mistakes and reduced set-up time.
- Easy pre-season testing, low drop-out rate. The automatic sole lug design and the precise centering of the toe pincer system mean: fewer correction factors will be needed and less time spent testing.
- The SINGLE CODE system gives you a super fast option for binding-to-boot adjustment: set the heel length using the special sole length scale. Forward pressure will be right on, first time, every time.
- All models have automatic lug height adjustment which accommodate standard differences in boot sole-height.
- Easy, hand- levered "ONE TOUCH"- set up. One tool adjustment, easy to turn adjustment screw, "easy-in" boot feature.
- Almost maintenance-free, easy to change the AFD, clean and lubricate the heel track. ELAN made the commitment to offer a comprehensive product and service program.

THE RENTAL BINDINGS

No single rental binding can ever fulfill all the needs of all types of shops. We therefore offer the following line up of rental/demo models.

SYMPRO:

THE BINDINGS THAT HELP YOUR HIGH PERFORMANCE SKI SET-UP:

ESP 10.0 GW ESP 10.0 GW TRACK

- Hand lever-adjusted heel (60 mm) and toe (64 mm)
- 7-toe positions
- DIN-ranges from 2.5 up to 10 that accommodate even high level skiers
- Short, lightweight heel track, despite wide adjustment range
- SINGLE CODE: "A-6" for ski boots from 263-391 mm sole length
- Replaceable brake
- Diagonal toe
- Optimal for Carving skis, minimized deviation between ski and boot mounting point
- Fully GripWalk compatible - no further height adjustment necessary



SYMRENT:

ESR 10.0 GW

A technically proven workhorse for the discerning skier who rents

- DIN range of 2.5 up to 10
- Diagonal toe
- Large 84 mm heel adjustment range
- SINGLE CODE "A-V" only ESR 10 GW
- Automatic toe and heel height adjustment
- "ONE TOUCH"- Hand lever adjustment for the heel
- Replaceable brake.
- Fully GripWalk compatible - no further height adjustment necessary

NOTES:

TECHNICAL INFORMATION

ELAN RENTAL LINE 2024/25

Model	Ramp angle	Z - DIN	kg	lbs	Set-Weight [g]	Jig	Feature	Toe					Heel					Boot Sole				
								Type	System		AFD	Stand Height [mm]	Length Adj. Range [mm]	Type	Heel System	Brake	Brake Code	Stand Height [mm]	Material Housing	Length Adj. Range [mm]	Length [mm]	DIN/ISO Standard
RENTAL																						
ESP 10.0 GW W/O Brake [D]	5,0	2,5 - 10	from 26	from 57	1290	SP 2003 W	Sympro	TX BTR	Full Diagonal		AFS GW	26		NX	Rental	W/O Brake [D]	D	31	GFK	60	263-391	A, GWA
ESP 10.0 GW TRACK	5,0	2,5 - 10	from 26	from 57	1290	SP 2003 W	Sympro	TX BTR	Full Diagonal		AFS GW	26		NX	Rental			31	GFK	60	263-391	A, GWA
ATTACK 14 MIN DEMO W/O Brake [F]	3 - 7	4 - 14	from 42	from 92	1245*	Attack Demo	ATTACK DEMO	FR PRO3	None		AFS metal MN	25 - 29	60	NX FR	Standard	W/O Brake [F]	F	32	GFK	60	259-382	A/GW A/T
ATTACK LYT 11 GW DEMO W/O Brake [F]	4,0	3 - 11	from 31	from 67	1160*	Attack Demo	ATTACK DEMO	FR LYT	None		AFS GW	28		SX FR	Standard	W/O Brake [F]	F	32	GFK	60	259-382	A/GWA

A: Alpine Adults, A/C: Alpine Adults and Alpine Children, A/GW A: Alpine Adults and GripWalk Adults, A/C/GW A/GW C: Alpine Adults, Alpine Children, GripWalk Adults and GripWalk Children, A/GW A/T: Alpine Adults, Gripwalk Adults and Touring

TECHNICAL INFORMATION

DEALER ONLINE SUPPORT

A fresh new look – the redesigned ELAN website has a great modern vibe, a perfect match for our innovative products and our skiers' desire to Access All Areas. With interactive and user-friendly features and tons of useful information, the site offers you the top online service for dealers, ski manufacturers as well as consumers.

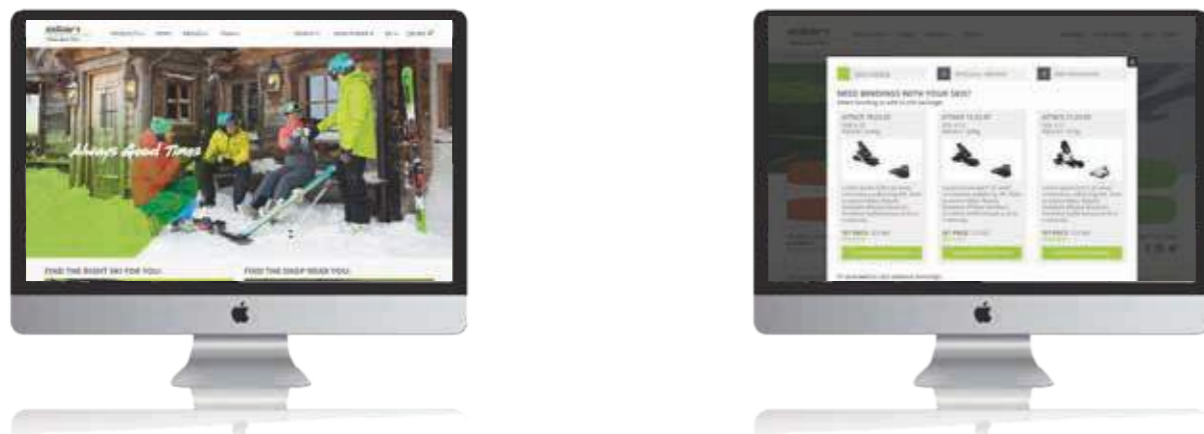

WWW.ELANSPO RTS.COM

It is the perfect gathering place for everyone interested in the ELAN binding collection, finding out more about their technical innovations or about the company itself and the ELAN history and milestones! The common thread is a desire to **Access All Areas** of any mountain!



CERTIFICATION SITE

training.elansports.com

At Elan's product training website (b2b.elanskis.com) you'll find everything you need to enhance your knowledge and provide exceptional service to our customers. Access our comprehensive technical manual for detailed product information, stay current with the latest binding certification tests to ensure safety and performance, and fine-tune your skills by watching informative product and sales clinic videos, designed to help you understand the features and adjustment of Elan products.

CALCULATOR APP

The Calculator App is designed to make the DIN setting process as easy as possible. You will find the App typing calculator.tyrolia.com into your browser. This works on all devices. If you are using a mobile device you will be asked if you want to save the App to your homescreen. After opening the App and reading the disclaimer, enter all the required information and the appropriate DIN setting will appear on your screen. As we have switched to a webbased app solution, the Calculator App is no longer available on the common App stores for download. If you still have our old App on your smartphone, you can continue to use it. **ONLY CERTIFIED ELAN SKI MECHANICS ARE ALLOWED TO USE THIS APPLICATION. IT IS FOR INFORMATION PURPOSES ONLY AND MAY NOT BE FORWARDED OR OFFERED TO OTHERS.**

TECHNICAL INFORMATION

JUST ONE CLICK

SEARCHING FOR SPARE PARTS AND TECHNICAL DATA AS SIMPLE AS POSSIBLE

The new OMS Spare Part Management (on line WEB access) offers all relevant information about ski bindings, technical data and their (spare) parts at a glance – and just one click away. Extensive information is available via the new OMS spare part system: Starting with the appropriate drill template right up to screws and spare parts related to a specific binding model; for example different brake types – plus, all parts can be directly identified by model. Pictures and colored marks provide simple navigation tools and easy recognition of selected parts.

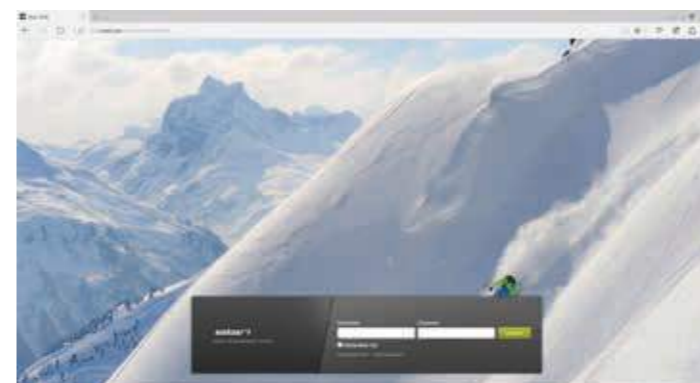

LOGIN

Run your browser, type in address field <https://oms.head.com> and you are ready to go... Pages are protected! To access type:

User name: spare_ELAN

Password: omsnew

You can download complete User Manual from web page <http://training.elanskis.com/>

TWO DIFFERENT MODES

You may navigate through the Spare Parts OMS via two different modes:

1. Product view mode
2. Spare Part view mode

With the product view, all existing spare parts related to a specific binding model can be identified. In the spare part view, all spare parts are listed with their designated use.



SPARE PART VIEWER

The Spare Part Viewer explains all spare parts in detail (text and pictures) and shows the appropriate article number, description and order quantity. Colored bars and marks of the requested part make navigation extremely simple and easy.



TECHNICAL DATA

In the "product view" mode, technical data is available as additional information. You may access this data by clicking on the spanner symbol. You will find this symbol in the spread-sheet between the picture preview symbol and the symbol which opens the spare part viewer (the toothed wheel symbol). You can access the technical data sheet of one specific binding model, or open the technical data catalogue for all models per line and season.

Technical Data for all ELAN lines from season 2009/2010 up to the current line is available online.

ONLINE HELP

A HELP Document is also available online. You will find it in the OMS in the top right corner.



TECHNICAL INFORMATION

PRODUCT PREPARATION

Product preparation is of a high importance for every user. All ELAN Skis are engineered and produced according to the actual ISO standards for alpine skis, but even the best manufactured product with the best materials used will not perform well if minimal preparation and maintenance rules are not followed.

1. TUNING

Each and every ski needs to be tuned properly and regularly to maintain its performance and safety. Factory tuning is done on industrial machinery and cannot be copied manually. Only authorized people with knowledge about the handling of service machines should service the skis.

Sintered bases require more frequent waxing but are harder and more resistant to impact damage; extruded bases are less demanding as far as waxing is concerned, but due to their softness may require more frequent repairs of impact damage. Steel edges are to be sharpened once the edge grip gets less strong or the edges are damaged. Even after only a few days of skiing on ice, the skis can significantly lose their edge grip.

For the tuning of ELAN skis we recommend the following edge geometry:

Angle from base: $1^{\circ} \pm 0,3^{\circ}$

Angle from side: $2^{\circ} \pm 0,5^{\circ}$

For Models:

All Ace models,
Ace GSX Master 174 & 179 cm,
we recommend following edge geometry:
Angle from base: $1,2^{\circ} / 0,8^{\circ} / 1,2^{\circ} \pm 0,3^{\circ}$



Angle from side: $3^{\circ} \pm 0,5^{\circ}$

For all Primetime models, all Wingman models and all Wildcat models (except Wildcat 76 C) we recommend following edge geometry:

Angle from base: $1^{\circ} \pm 0,3^{\circ}$

Angle from side: $3^{\circ} \pm 0,5^{\circ}$

2. DRILL BITS

Proper binding installation is essential for the optimal performance of the product and proper binding function. Follow the chart of catalogue ski models below regarding the diameter of the drill-bit and depth of drilling. Holes must be sealed with glue. Please, contact the local distributor for non-catalogue models.

DRILL BIT	SKI
Ø4.1 x 9.0 mm	Bloodline, FX DHX, FX SGX, FX SGJ GSX WC, GSX WC X, SLX WC, GSX Team (>140cm), SLX Team (>140cm) Wingman 86 CTi, 86 Ti, 82 CTi, 82 Ti Wildcat 86 CX, 82 CX, 82 C Slingshot
Ø3.6 x 9.0 mm	Ripstick 96 Black Edition, 102 Black Edition, 94 W Black Edition, 116, 108, 96, 88, 100 W, 94 W, 88 W Ripstick 86 T, 86 TW Ripstick Tour 104, 94, 88, 94 W, 88 W, 80T (≥ 150 cm) Playmaker 91, 101, 111 Lynx 65 UL Playmaker 81 T
Ø4.1 x 7.0 mm	SLX Team (≤ 140 cm), GSX Team (≤ 140 cm), RCX
Ø3.6 x 7.0 mm	Playmaker U-Flex, Ripstick Tour 80T (< 150cm)

3. MOUNTING POSITIONS

The mounting position is usually close to the gravity point of the ski. Any variation towards the tip will make the ski more aggressive and quicker to turn any variation towards the tail will make it accelerate better out of turn.

4. MOUNTING POSITIONS FOR SKIS

This measurements should be taken from the tail of the ski and indicate the boot center. All measurements are in millimeters. Acceptable tolerance ± 1.5 mm

TECHNICAL INFORMATION

MOUNTING POSITIONS FOR MODELS 2024/25

RACE COMPETITION	Length	185	188	191	193
GSX WC	Mounting pos.	/	820	/	825
GSX WC X	Mounting pos.	805	/	810	/

	Length	157	165
SLX WC	Mounting pos.	670	710

	Length	174	181	191
FX SGJ	Mounting pos.	745	775	820

	Length	201	205	210	211	218
FX SGX	Mounting pos.	870	890	/	920	/
FX DHX	Mounting pos.	/	/	915	/	960

	Length	125	141	158	170	175	181	191
Bloodline	Mounting pos.	515	595	670	740	770	800	850

	Length	145	151	166	171	176	182
GSX Team	Mounting pos.	/	/	740	765	745	820
SLX Team	Mounting pos.	620	655	/	/	/	/

	Length	134	142	150	158
GSX Team	Mounting pos.	580	615	655	692

	Length	122	128	133	139
SLX Team	Mounting pos.	/	/	558	590
RCX	Mounting pos.	514	540	/	/

ALL MOUNTAIN WINGMAN	Length	160	166	172	178	184
Wingman 86 CTi	Mounting pos.	728	752	781	810	838
Wingman 86 Ti	Mounting pos.	728	752	781	810	838
Wingman 82 CTi	Mounting pos.	710	740	770	800	830
Wingman 82 Ti	Mounting pos.	710	740	770	800	830

W STUDIO ALL MOUNTAIN WILDCAT	Length	146	152	158	164	170
Wildcat 82	Mounting pos.	660	690	720	750	780
Wildcat 86	Mounting pos.	/	704	728	752	781

FREERIDE RIPSTICK	Length	147	154	161	168	175	182	185	189	193
Ripstick 116 RE	Mounting pos.	/	/	/	/	/	/	860	/	900
Ripstick 108	Mounting pos.	/	/	725	760	795	830	/	870	/
Ripstick 102	Mounting pos.	/	/	725	760	795	830	/	870	/
Ripstick 96	Mounting pos.	/	/	725	760	795	830	/	870	/
Ripstick 88	Mounting pos.	/	690	725	760	795	830	/	870	/
Ripstick 102 Black Edition		/	/	725	760	795	830	/	870	/
Ripstick 96 Black Edition		/	/	725	760	795	830	/	870	/
Ripstick 106W	Mounting pos.	/	700	735	770	805	/	/	/	/
Ripstick 100W	Mounting pos.	/	700	735	770	805	/	/	/	/
Ripstick 94W	Mounting pos.	665	700	735	770	805	/	/	/	/
Ripstick 88W	Mounting pos.	665	700	735	770	805	/	/	/	/

BACKCOUNTRY RIPSTICK TOUR	Length	156	157	163	164	166	170	171	173	177	178	180	184	185	187
Ripstick Tour 104	Mounting pos.	/	/	/	/	745	/	/	785	/	/	820	/	/	845
Ripstick Tour 94	Mounting pos.	/	695	/	730	/	/	775	/	/	810	/	/	845	/
Ripstick Tour 88	Mounting pos.	685	/	720	/	/	755	/	/	790	/	/	825	/	/

	Length	156	157	163	164	170	171	177	178
Ripstick Tour 94 W	Mounting pos.	/	695	/	730	/	775	/	810
Ripstick Tour 88 W	Mounting pos.	685	/	720	/	755	/	790	/

BACKCOUNTRY RIPSTICK TOUR TWEENER	Length	120	130	140	150	160
Ripstick Tour 80 T	Mounting pos.	508	558	608	658	708

ALL MOUNTAIN TWEENER	Length	138	148	158	168
Ripstick 86 TW	Mounting pos.	600	650	700	750
Ripstick 86 T	Mounting pos.	600	650	700	750

FREERIDE TWINTIPS	Length	156	164	172	180	188
Playmaker 91	Mounting pos.	720	760	800	840	880
Playmaker 101	Mounting pos.	/	760	800	840	880
Playmaker 111	Mounting pos.	/	/	800	840	880

SPEED-TOURING LYNX	Length	150	157	160	164	171	178
Lynx 65 UL	Mounting pos.	650	/	700	/	/	/
Lynx 82	Mounting pos.	650	680	/	710	740	770
Lynx 82 W	Mounting pos.	650	680	/	710	740	770
Lynx 82 UL	Mounting pos.	650	680	/	710	740	770

FREESTYLE	Length	136	146	156	166	176
Playmaker 87	Mounting pos.	630	680	730	780	830

FREESTYLE JR.	Length	125	135	145	155	165	175
Playmaker 81T	Mounting pos	606	655	705	750	800	850



ADJUSTMENT

ADJUSTMENT CLASSIFY YOURSELF

DETERMINING YOUR SKIER TYPE IS YOUR RESPONSIBILITY!

Your Skier Type, height, weight, age and boot sole length are used by the shop technician to determine the release/ retention settings for your bindings. Consult these descriptions to select your classification. Be sure to provide accurate information. Errors increase your risk of injury.



TYPE I

Skiers who designate themselves as type 1 receive lower than average release settings. This corresponds to an increased risk of inadvertent binding release to have releasability in a fall. This type also applies to entry-level skiers uncertain of their classification.

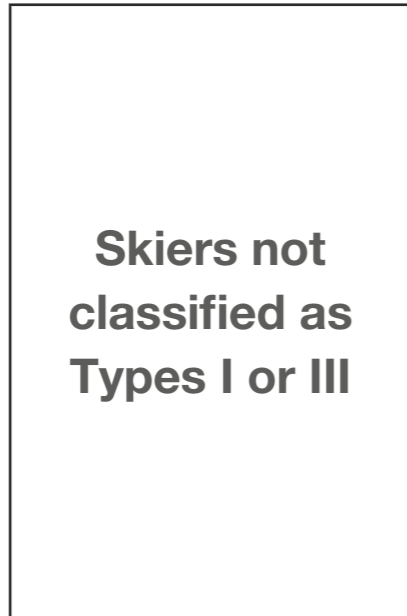

Skiers not classified as Types I or III

TYPE II

Skiers who designate themselves as TYPE II receive average release settings suitable for most recreational skiers.



TYPE III

Skiers who designate themselves as TYPE III receive higher than average release settings. This corresponds to decreased releasability in a fall to have a decreased risk of inadvertent binding release. TYPE III settings should not be used by skiers of less than 22 kg/48 lbs

If you are unsatisfied with the release/retention settings that result from your classification please mention this to your binding technician.

NOTE: If the skier reports release/retention problems see the chapter "troubleshooting release/retention problems", page 36 in the manual. Skiers who desire release/retention settings lower than Type I may designate themselves **(I-)**. **Type I-** is inappropriate for skiers 17 kg/38 lbs or less. **Type I-**: Move up the table one skier code.

Skiers who desire release/retention settings higher than Type III may designate themselves **(III+)**. **Type III+**: Move down the table three skier codes.

Skiers may select skier type designations that are different for twist and forward lean. In such a case, the selection shall be indicated by a slash separating twist and forward lean selections, in that order (for example, K/L, K for the toe and L for the heel.

ADJUSTMENT RELEASE/RETENTION ADJUSTMENT TABLE

NOTE: The initial indicator values found in this table are only the starting point in the binding setting process. The initial values may need to be modified in order to achieve the correct measured release values.

				1	2	3	4	5	6	7	8	
				Single Code								
kg (lbs)	cm (ft 'in")	Skier Code	Mz (Nm)	My (Nm)	a - i	j - n	o - s/B	t/C - G	H - L	M - Q	R - V	V - 6
			5 ^a	18 ^a	≤ 230	231-250	251-270	271-290	291-310	311-330	331-350	> 351
10-13 kg (22-29 lbs)		A	8	29	0,75	0,75	0,75					
14-17 kg (30-38 lbs)		B	11	40	1,00	0,75	0,75	0,75				
18-21 kg (39-47 lbs)		C	14	52	1,50	1,25	1,25	1,00				
22-25 kg (48-56 lbs)		D	17	64	2,00	1,75	1,50	1,50	1,25			
26-30 kg (57-66 lbs)		E	20	75	2,50	2,25	2,0	1,75	1,50	1,50		
31-35 kg (67-78 lbs)		F	23	87	3,00	2,75	2,50	2,25	2,00	1,75	1,75	
36-41 kg (79-91 lbs)		G	27	102		3,50	3,00	2,75	2,50	2,25	2,00	
42-48 kg (92-107 lbs)	≤ 148 cm (≤ 4'10")	H	31	120			3,50	3,00	3,00	2,75	2,50	
49-57 kg (108-125 lbs)	149-157 cm (4'11"-5'1")	I	37	141			4,50	4,00	3,50	3,50	3,00	
58-66 kg (126-147 lbs)	158-166 cm (5'2"-5'5")	J	43	165			5,50	5,00	4,50	4,00	3,50	3,00
67-78 kg (148-174 lbs)	167-178 cm (5'6"-5'10")	K	50	194			6,50	6,00	5,50	5,00	4,50	4,00
79-94 kg (175-209 lbs)	179-194 cm (5'11"-6'4")	L	58	229			7,50	7,00	6,50	6,00	5,50	5,00
≥ 95 kg (≥ 210 lbs)	≥ 195 cm (≥ 6'5")	M	67	271				8,50	8,00	7,00	6,50	6,00
		N	78	320				10,00	9,50	8,50	8,00	7,50
		O	91	380				11,50	11,00	10,00	9,50	9,00
		P	105	452						12,00	11,00	10,50
			121	520								
			137 ^b	588 ^b								

a...Lowermost tolerance limit
b...Uppermost tolerance limit

HOW TO USE THE RELEASE/ RETENTION ADJUSTMENT TABLE:

- Determine the Skier Code by locating the skier's weight in the first column and the skier's height in the second column. If the height and weight are not on the same line select the Skier Code closer to the top of the chart.
- Find the column that corresponds to the skier's boot sole measurement in millimeters.
- The value where the Skier Code and the boot sole measurement intersect is the initial indicator setting for the skier.
- If the intersection of the row and column falls in a blank box, do not move up or down the chart. Move sideways on the same row to the nearest box showing a visual indicator setting.
- This value should be recorded on the Elan equipment rental form under Initial Indicator Settings.

MECHANICAL SYSTEM TESTING

1. Adjust the bindings toe and heel indicators to the Initial Indicator Setting.
2. Use a calibrated torque measuring device according to the instructions provided by the supplier.
3. Precondition binding by releasing it at least once in all directions.
4. Three tests are required in each direction. The middle quantitative value of the three releases should be used as the test result.
5. Using the previously determined Skier Code slide across the chart to the column representing twist torque reference values.
6. If the test result is within one torque value above to one torque value below the reference value, it is in the Inspection Range. These results are acceptable and no further adjustment is necessary. For detailed Mechanical testing procedure please check Mechanical testing video on Elan certification site training.elansports.com.
7. If the test result is within two torque values above to two torque values below the reference value, it is in the In-Use Range. The indicator value should be readjusted and the system retested so that it falls in the Inspection Range. Record the corrected indicator value in the box for final release/retention settings.
8. If the test result value falls out of the In-Use Range the system should be thoroughly inspected for the following:
 1. Correct forward pressure
 2. Correct Sole-hold down adjustment
 3. Worn or contaminated AFD's
 4. Out of standard boot solesNo work can be performed on the system until these problems are corrected.
9. Check the heel for forward lean the same way, determining the middle quantitative value of three vertical releases. Adjust if necessary.
10. Record final indicator settings on the Elan equipment rental form in the area for final release/retention settings

TROUBLESHOOTING RELEASE/RETENTION PROBLEMS

IF THE SKIER REPORTS A RELEASE/RETENTION PROBLEM:

- Re-inspect the equipment to make sure that all components are in good condition and function properly.
- Test the system to make sure that it is calibrated properly.
- Have the skier use the "Classify Yourself" materials to make certain that the correct Skier Type has been selected

If component inspections and a calibration check do not reveal a problem the skier may be requesting discretionary settings.

INFORMATION FOR SKIERS REQUESTING DISCRETIONARY SETTINGS.

1. Your normal release/retention settings comply with ISO/ASTM standards. Although these guidelines may be inappropriate for some types of competitive skiing or competition training, they are believed to provide an effective compromise between the release and retention needs of most recreational skiers.
2. Adhering to these guidelines may help to reduce the risk of injuries resulting from improper release/retention setting selection. However, skiing involves inherent risks. Injury can result from simply falling down, impact with an object, or from many other actions. Many injuries are unrelated to the function of the release system. Furthermore, even a properly adjusted binding cannot protect the skier in all situations.
3. Difficulties with release or retention may be unrelated to release/retention settings and can result from your skiing style, the incompatibility of your boots and bindings, or wear, damage, or contamination of a component of the release system. Be sure to describe your circumstances to the shop technician and to authorize recommended inspections and repairs before proceeding.
4. If skier has been dissatisfied with the release/retention settings that result from his normal skier classification, he/she may wish to consider changing skier classification, or designating skier type classifications that are different for twist and forward lean. Skier may even request discretionary release/retention settings that are outside of his/her setting range. If skier believes that he/she requires higher release/retention settings but is unsure if the increase should be applied to twist or forward lean settings, skier should request that the increase be applied to forward lean settings before experimenting with higher twist settings. Similarly if skier believes that he/she requires lower release/retention settings but is unsure if the decrease should be applied to twist or forward lean settings, he/she should request that the decrease be applied to twist settings before experimenting with lower forward lean settings. Lower settings correspond to an increase in the risk of inadvertent binding release in order to gain increased releasability in a fall. Higher settings correspond to a decrease in releasability in a fall in order to gain a decreased risk of inadvertent binding release.
5. Although the shop technician may help skier to record your choice on the appropriate form, the final decision on release/retention settings is made by skier.

ADJUSTMENT

RENTAL-TEST AND INSPECTION PROCEDURES

PREPARING AND CHECKING RENTAL SYSTEMS

Customers usually don't treat rental equipment as gently and carefully as they would handle their private property.

In order to keep your rental fleet as functional and appealing as possible, a systematic maintenance program is a must. The best results are obtained with an ongoing program that constantly checks boots, bindings and skis. To keep the equipment in good condition while minimizing liability we recommend the following program (this is a requirement in the U.S.). In order to produce a truly efficient rental inventory some pre-season setup is required.

As of May 2022, ASTM testing procedures no longer allow for correction factors to be used in the adjustment of rental bindings.

SINGLE CODING

This enables a quick binding to boot adjustment even during the rush hours of rental business. ELAN offers self-adhesive color stickers (Art. No. 162561) with the SINGLE CODE to be applied before season. You simply check the boot's SINGLE CODE and adjust the binding accordingly. In order to gain the efficiencies of SINGLE CODE, all you need to do is follow our simple procedure.

1. Mount all bindings according to the ELAN manual. Pick a mounted sample binding of each model.
2. Place a boot of each size in the binding and adjust forward pressure until correct.
3. Open the heel and remove boot.
4. Record the SINGLE CODE from the track on the side of the heel housing. (The boot must not be in the binding when you read the code).
5. Check each code again before marking all boots of this size with their SINGLE CODE (Pict. 1)

You can get SINGLE CODE stickers as a spare part. "SINGLE CODE" sticker set Art. No. 162561.

For this procedure the Rental Boot Indicator (Art. No. 162617) can be used.



RENTAL INSPECTION SUMMARY

Since it is impractical to perform a full inspection each time a system is rented, a routine of preseason and in-season inspections has been

developed to verify release indicator accuracy, confirm correct equipment function, and assure proper assembly and adjustment procedures by the rental shop staff. Fully implemented, the procedures that follow provide rental shop customers a standard of care equivalent to that provided retail shop customers under current ISO and ASTM standards. The program is based on standards: ISO 13993 and ASTM F1064. The rental procedure is not applicable for complete and incomplete alpine ski-binding-boot systems which are rented 15 days or more and for alpine touring ski-binding-boot systems.

PRE-SEASON INSPECTION

Prior to the beginning of each season and whenever new inventory is added, an inspection should be made of the components of the release/retention system (binding-boot) in accordance with the procedure described in this manual. Bindings that fail go through a troubleshooting procedure to identify and correct the deviation or malfunction. If this procedure does not correct the problem, the binding is removed from inventory. All rental boots, new and used, are visually inspected for damage, wear, contamination, broken or missing parts, or inferior materials at contact points with the binding. If a boot fails, a 16 system (or less if 16 systems are not available) random sample is also tested. If any boot in this sample creates a deviation greater than the inspection color all boots from that cell are then tested. Boots that fail and cannot be repaired are removed from inventory.

IN-SEASON INSPECTION

At regular intervals during the season, samples are taken from the rental inventory and evaluated in accordance with the procedures described in this manual. In-season inspections are performed on complete rental systems to ensure that the equipment is adjusted appropriately and continues to function correctly.

IMPORTANT TERMS

DIRECTIONS OF RELEASE

Unless otherwise specified (see In season Inspection), the directions of release to be tested are forward lean, clockwise and counter clockwise in twist.

TEST DEVICE

A device which meets ISO standard 11110 or ASTM standard F1061 and has been checked and maintained in the manner specified by the device manufacturer.

TEST RESULT OR RELEASE TORQUE

The middle quantitative value of three tests made in the same direction.

SYSTEM BINDING

A binding that is slid onto a pre-mounted or integrated track without drilling.

PRE-MOUNTED BINDING

A binding that is already mounted on the ski before being delivered to the shop.

REFERENCE BOOT SELECTION

The Reference Boot is a boot of a designated sole length which is otherwise typical of the boot inventory.

PRE-SEASON TEST

PRE-SEASON BINDING SAMPLING

All bindings, new or used are visually inspected.

1. For factory new pre-mounted or sealed system bindings (Fusion X, Shift or Junior Shift JRS) a 5% sample (not less than 16 nor more than 80 systems) of each "cell" is tested using a specially selected reference boot. A cell is all bindings of the same make, model and year. Although sampling eliminates the need to test every binding before the season starts, the sample chosen must be representative of the inventory.
2. For any other new bindings and all used bindings, all bindings of the inventory are inspected.

REFERENCE BOOT SELECTION

The Reference Boot is a boot of a designated sole length which is otherwise typical of the boot inventory. Use the procedure below if the boot inventory includes several models and a representative boot cannot easily be identified.

1. Select five single boots with sole lengths as specified in Table [A] for the binding type to be tested: adult, junior, child.
2. Clean all five boots with a mild detergent and water.
3. Adjust a rental binding to the release indicator setting specified in Table [A] for the binding type.
4. Fit the binding to the boot and determine the Release Torque in all three directions of release (forward lean and both directions in twist-three releases in each direction).
5. Average the Release Torque for CW (clockwise) and CCW (counter clockwise) twist release.
6. Reject and replace any boot with a CW to CCW difference of more than 6 Nm for adult boots or 4 Nm when testing child boot types.
7. Rank the five twist results and select, as the Reference Boot for twist, the middle boot.
8. Rank the five forward lean results and select, as the Reference Boot for forward lean, the middle boot.

PRE-SEASON BINDING INSPECTION

The procedure that follows is an integral part of pre-season maintenance. It is also a good way to determine if maintenance was successful and which units have outlived their usefulness and must be removed from inventory.

1. Clean areas of the bindings that contact the boot and perform all preseason binding maintenance.
2. Visually or manually check:
 - a.) AFD condition.
 - b.) Brakes function.
 - c.) Release indicator readability and travel
 - d.) Screw tightness.
3. Adjust each binding with the reference boot, then adjust the release value indicators to the specified value found in table [A].
4. Check that the heel track and toe track Single Code agree with the sole length Single Code of the reference boot.
5. With the Reference Boot in the binding, verify elastic travel of the toe piece by striking the boot toe with a mallet or dead hammer and checking that the toe piece returns the boot quickly and completely to center.
6. Verify elastic travel of the heel piece by lifting the boot while depressing the heel piece cocking lever and checking that the heel piece returns the boot quickly and completely to the latched position.
7. Manually release the binding 3 times in each direction.
8. Lubricate all boot/binding interfaces with a mild liquid detergent and

water solution.

9. With the Ski Binding Test Device determine the Release Torque for each direction of release (forward lean and both directions in twist).
10. Record "PASS" in the bindings maintenance record if test results are within the Inspection range provided in Table [A].
 - 11.a. If the test results of any binding from the before taken sample for factory pre-mounted or sealed system bindings is outside the Inspection range in Table [A], every binding of the same cell is tested.
 - 11.b. Set aside the binding if the test result in any directions of release is outside the Inspection range in Table [A].
12. Follow Troubleshooting Procedure on page 97-98 for units which have been set aside and retest if changes in the unit's condition or adjustment are made.
13. Record "FAIL" in the binding's maintenance record if, after troubleshooting, test results in any direction of release are outside the inspection range. Remove the "failed" unit from the inventory.
14. If many bindings fail, check the test device and reinspect the Reference Boot. If necessary, select another boot and retest the bindings.

PRE-SEASON BOOT PREPARATION

The procedure that follows is an integral part of pre-season maintenance.

1. Clean all boots with a mild detergent and water, and repair or replace damaged or missing parts.
2. Visually check:
 - a.) Compliance with ISO and other applicable standards ISO 5355. If the boot contacts the binding, brake, or AFD in areas other than the designated contact points, it may be incompatible with the binding.
 - b.) Boot material. If the sole at the contact points with the binding or AFD can be scratched with a finger nail, the boot may be of inferior quality and incompatible with the binding.
 - c.) Boot sole condition. If the boot sole is damaged, worn or contaminated at contact points with the binding or AFD in a manner which cannot be corrected, the boot may be incompatible with the binding, "Verify boot sole dimensions" on page 92.
 - d.) Brake compatibility with sole.
 - e.) Rubber and/or metal sole protectors. If such materials contact the binding or AFD the boot may be incompatible with the binding.
 - f.) Mold flashings. Flashing which can be seen or felt at contact points with the binding, brake, or AFD must be carefully removed.
3. Remove from inventory all boots that have failed the visual check.

PRE-SEASON BOOT SAMPLING

Although sampling eliminates the need to test every boot before the season starts, the sample chosen must be representative of the inventory.

1. For boots that are new to inventory or have never been inspected, take a single boot from each cell (a cell is all boots of the same make, model, year, and shell size).
2. For used boots, take a 5% (but not less than 16 or more than 80) random sample of the entire inventory, see Table [B]. Make sure that there is at least one boot from each cell in the sample.

PRE-SEASON BOOT INSPECTION

The procedure that follows helps to assure boot/binding compatibility and boot interchangeability.

	Skier Code	Binding Type	Boot sole length [mm]	Release Indicator Setting	Reference Torque Twist [Nm]	Reference Torque Forward [Nm]	Twist Inspector Range [Nm]	Forward Inspection Range [Nm]	Twist In-Use Range [Nm]	Forward In-Use Range [Nm]
Alpina DSS Junior	B	Children	194	1,00	11	40	8 to 14	29 to 52	5 to 17	18 to 64
	D	Children	219	2,00	17	64	14 to 20	52 to 75	14 to 23	40 to 87
	F	Children	245	2,75	23	87	20 to 27	75 to 102	17 to 31	64 to 120
	H	Children	272	3,00	31	120	27 to 37	102 to 141	23 to 43	87 to 165
	I	Children	290	4,00	37	141	31 to 43	120 to 165	27 to 50	102 to 194
	F	Children	260	2,50	23	87	20-27	75-102	17-31	64-120
	J	Junior	300	4,50	43	165	37-50	141-194	31-58	120-229
	L	Adult	320	6,00	58	229	50-67	194-271	43-78	165-320

Table [A] Pre-season binding inspection

NOTE: when using Table [A] in the Boot Inspection procedures that follow, the Sole Length and release Indicator Setting columns should be ignored.

1. Randomly select a pair of bindings that have passed the preseason inspection from each binding type: adult, junior, child.
2. Lubricate all boot/binding contact points with a mild liquid detergent.
3. Without regard to whether the boot is new or used, sort the sample by sole type and length according to the 20 mm Sole Length Categories defined by the Release/Retention Adjustment Chart.
4. In each Sole Length Category rank the boots by sole length and select the middle boot.
5. In each Sole Length Category fit the appropriate reference bindings to this "typical" boot and adjust the two bindings to release as close as practical to the Reference Torque in Table [A]. Use the Reference Torque corresponding to Skier Code [L] for the Adult binding, [J] for Junior binding, and [F] for the Child binding. (Reference [B]- black, yellow, silver; [C] - red triangle, blue square, black diamond, white circle)
6. Rinse the lubricant from one binding and mark it "clean". Mark the other "lubricated".
7. Test each boot in the Sole Length Category with the clean Reference Binding and then the lubricated Reference Binding in both twist and forward lean (only one direction in twist is required for the clean binding).
8. Set aside any boots for which the lubricated Test Result is more

than 20% less than the clean Test Result in the same direction of release or the lubricated Test Result in any direction of release is outside of the Inspection range provided in Table [A], for Skier Code used to set up the Reference Binding (Reference [A] - F, J).

- 9.a For a new boot that fails, check a 16 system (or less if 16 are not available) random sample of the boots of the same cell (make, model, year, and shell size) as those that failed. If any boot of these samples creates a deviation greater than the Inspection range, check all other boots from the same cell.
- 9.b For used boots, if any boot of the sample creates a deviation greater than the Inspection range, check all other boots from the same cell.
10. Check all other boots from the same cell (make, model, year, and shell size) as those that failed.

NOTE: On completion of the preseason inspection, clean the liquid detergent from equipment and lubricate the binding before returning it to service.

IN-SEASON SAMPLING AND INSPECTION

The in-season Inspection is a test of complete systems and all the procedures used by the rental staff to assemble and adjust the system. The program uses random samples of rental inventory taken at routine intervals. Any sampling program that gives every unit of inventory the

same chance as every other of being picked is valid.

SAMPLE FREQUENCY

Random sampling is conducted throughout the entire season. Frequency is as follows:

1. After 7 days of operation.
2. If the sample passes the next sampling is taken after another 7 days operation.
3. If two consecutive samples pass, sampling frequency is increased to 14 days (reduced sampling schedule).
4. If a sample fails at any time, daily sampling is instituted until two consecutive samples pass, at which point weekly sampling resumes.

Facilities that have an average daily output of fewer than 160 rental skier days/day (averaged on a weekly basis) may adopt an alternate procedure and sample, over the sampling interval, 5% of average daily output, and delay evaluation of the inspection results until a total of 16 sampled units is detected at any time, corrective action should be taken. This alternative method is used with a normal (weekly) or daily sampling schedule but is inappropriate for a reduced schedule.

SAMPLE SIZE

Sample size is 5% of inventory but not less than 16 nor more than 80 units as noted in Table [B]. Sample size may be based on average daily output if rental output drops below 50% of capacity over the sampling period. The sample is taken at any time during the sampling interval or may be spread over the period. The sample represents both inventory available for rental and equipment in the condition in which it is returned, with an equal number of units drawn of each group. All units within such sample should be selected randomly.

IN-SEASON INSPECTION

1. Take a random sample of the rental inventory as determined by Table [B]. Take half the sample from inventory as it is either rented or returned and the remainder from inventory available for rental.
2. The returned samples are tested with the last customer's data, the other samples adjust to randomly selected skier data.
3. Wipe the boot clean and cycle the boot/binding systems at least once in each direction.
4. Test sample units in Twist (one direction only) and Forward Lean.
5. Compare the Test Results with the Inspection Range for the appropriate Skier Code, see ISO 11088 Release/ Retention Adjustment Chart (page 39).
6. If the results are within the Inspection Range, one value above to one value below the reference value, the unit passes.
7. If the results are outside Inspection Range but within the In-Use Range, count the unit to the number of systems within the In-Use range.
8. If the results are outside the In-Use Range, count the unit to the number of systems outside the In-Use range. count the unit as a range class II deviation. The cause must be identified and the entire rental inventory needs to be inspected.
9. Check elastic travel and visually inspect the ski brake function, interface areas between boot and binding, including AFD, lug height adjustment (if appropriate), and forward pressure.
10. If more than 20 % of the units in the sample produce results outside the inspection range but within the in-use range, or if a single

system produces results outside the in-use range, follow the manufacturers troubleshooting procedures and initiate daily testing.

11. Record the date the sample was tested, the number of units tested the number of results outside of the inspection range, the number of results outside of the in-use range, whether the sample passed or failed and any actions taken. There is no need to record the identity of units tested or actual Test Results.

RENTAL/DEMO OF INCOMPLETE SYSTEMS

Many shops rent their customers incomplete ski equipment systems. Boots only if customers provide their own skis with bindings, or skis and bindings if the customers provide their own boots. Additionally some shops utilize on-hill "demo days" as a means by which new products can be tested and evaluated by potential buyers.

In order to offer these skiers the same level of care as that afforded under the preceding procedures, the following guidelines should be used:

RENTAL OF SKIS/BINDING ONLY CUSTOMER - PROVIDED BOOTS

Although the retail test procedure may be applied in this case, it is often impractical to require actual system testing, especially in on-hill situations. In lieu of retail testing, the following procedures may be employed:

1. The ski/binding system to be rented or demoed should be tested "pre-season" using a boot which passes the Elan Boot Visual Inspection.
2. The skier's boot should also pass the Visual Inspection. If any questions exist regarding the quality of the boot, or if only the boot is rented retail-type testing should be used.
3. The binding should be adjusted and its indicators set per current Elan / Tyrolia recommendation.
4. A full record noting appropriate customer information and binding settings should be kept by the individual or organization responsible for the adjustment.
5. After seven days of use, the ski/binding system should be tested according to the In-Season Inspection Procedures previously described.

RENTAL OF BOOTS ONLY CUSTOMER PROVIDED SKIS/BINDING

If the customer provides their own skis and bindings, the rental procedure is not applicable. In this case, follow the approach according to ISO 11088 or ASTM F1063.

NOTE for US and Canada

Signatures of both the customer and Elan Certified Mechanic are required on all shop forms to qualify for the Elan Dealer Indemnity Program.

min.

max.

Inventory Size - pairs	50	100	200	300	400	500	600	700	800	900
Inventory Size - units (half pairs)	100	200	400	600	800	1000	1200	1400	1600	1800
Sample Size - units (half pairs)	16	16	20	30	40	50	60	70	80	80

Table [B]

NOTES:



MOUNTING

BINDINGS & PLATES

MOUNTING WORKSHOP TOOLS AND AIDS

To make your work easier, ELAN provides a variety of workshop tools and aids. Find the whole product range below. Furthermore ELAN / Tyrolia offers different templates for all available ELAN ski bindings and plates. Find the overview of the drill template selection on next pages. Referring to this overview you are able to determine easily which template should be used with which binding. Also find this information on the removable bench chart which is located inside the back cover of this Technical Manual or at the label on the binding box. For earlier lines, refer to the corresponding Technical Manuals or use the Online Spare Parts OMS to search for specific information.

Picture	Item	packed	Art.No.
	Drill Template Adapter-Set	per set	162569
	Drill 4.1 Ø x 7.0 mm long Drill 4.1 Ø x 9.0 mm long Drill 3.5 Ø x 7.0 mm long Drill 3.5 Ø x 9.0 mm long Drill-set complete	per piece per piece per piece per piece per set	162772 162773 162770 162771 162774
	Screwdriver flat Screwdriver incl. Pozidrive #3 Bit (160805) Slotted Screw Bit for Handy Ratchet Pozidrive #3 Bit for Handy Ratchet Pozidrive #3 Bit for electric driver (Black & Decker, Skill, Thor, Atlas-Copco, Virax, Consolidated, Bosch, Ingersoll-Rand), hexagon. 1/4" (6.35»mm) Pozidrive #3 Bit for electric driver (Bosch, Metabo, AEG), hexagon. 1/4" (5.5»mm) Torx bit 25/50 - 1/4 inch	per piece per piece per piece per piece per piece per piece 10 pieces	160806 162800 162575 162576 160802 160803 163066
	Special set for repairs (drill bit and plugs) Drill bit for repair set Special plastic plugs for repair set	per set per piece 50 pcs	162127 162128 162129
	Plastic plugs mixed Plastic plugs silver	500 pcs 500 pcs	160857 162856
	Service-Grease-Spray (500 ml) Grease Glue	per piece per piece per piece	162779 160052 160858
	Rubber band for brake	10 pcs	162562
	Rental Boot Indicator (Single Code, mm) Slide (replacement) for Rental Boot Indicator	per piece per piece	162617 162518
	SINGLE CODE Rental Boot Stickers (5 sheets)	per set	162561
	Height Adjustment Tester for AAA-Series and Freeflex ST	per piece	162983
	Write&wipe rental ski sticker	24 pcs	PSU10017000
	Rental sticker landing pad	20 pcs	PSU11017000
	ELAN screwdriver	2 pcs	PSM00413000
	Apron	2 pcs	PSM10013000

MOUNTING DRILL TEMPLATE SELECTION

All templates are equipped with extended clamping jaws and an enlarged range of the fixing mechanism. The STANDARD fixing mechanism ranges from 59 to 108 mm, the ADRENALIN, AMBITION, Attack DEMO and the TOUR PT mechanism from 75 to 125 mm and the FAT mechanism from 104 to 154 mm. For more versatility ELAN / Tyrolia offers a template adapter set to adapt the mounting range of your jig (see page 98).

DRILL TEMPLATE 92 W (162760) for ski widths from 59 to 108 mm
DRILL TEMPLATE 92 FAT (162868) for ski widths from 104 to 154 mm



BINDINGS:

ER 18.0 X RD FF ST, ER 17.0 FreeFlex ST, ER 11.0 FreeFlex ST, ER 14.0 FreeFlex ST, ER 11.0, Attack 17 MN, Attack 14 MN, Attack 11 GW, Attack 9 LYT GW, Attack 11 LYT, Attack 12 LYT

DRILL TEMPLATE AMBITION (163000) for ski widths from 75 to 125 mm
PLASTIC FOIL TEMPLATE AMBITION (163011)



BINDINGS:

AMBITION 12 MN

DRILL TEMPLATE Attack DEMO (163009) for ski widths from 75 to 125 mm
PLASTIC FOIL TEMPLATE Attack DEMO (163015)



BINDINGS:
Attack 14 MN DEMO, Attack 11 MN DEMO

DRILL TEMPLATE RACEPLATE WCR SHORT /TEAM (165253) for ski widths from 59 to 108 mm



BINDINGS:
RACEPLATE WCR SHORT 14, RACEPLATE WCR TEAM

DRILL TEMPLATE BASES & PLATES (162865) for ski widths from 59 to 108 mm



PLATES:
EP 9.0, EP 9.0+, Quick Trick Twin PR

DRILL TEMPLATE RACE PLATE 09 (162902) for ski widths from 59 to 108 mm



PLATES:
RACEPLATE EVO 14

DRILL TEMPLATE RACEPLATE WCR (165252) for ski widths from 59 to 108 mm



PLATES:
RACEPLATE WCR 14

DRILL TEMPLATE 94 W (162761) for ski widths from 59 to 108 mm



BINDINGS:
EL 4.5 GW CA

DRILL TEMPLATE FREELFLEX DEMO (163013) for ski widths from 59 to 108 mm



BINDINGS:
FREEFLEX DEMO 14 GW

DRILL TEMPLATE TOUR PT (163156) for ski widths from 75 to 125 mm



BINDINGS:
ALMONTE 12 PT, ALMONTE 10 PT, ALMONTE 10 PT DEMO

DRILL TEMPLATE SP 2003 W (162763) for ski widths from 59 to 108 mm



BINDINGS:
ESP 10.0 GW

DRILL TEMPLATE SR 2003 W (162762) for ski widths from 59 to 108 mm



BINDINGS:
ESR 10.0 GW

MOUNTING

DRILL TEMPLATE 92W & 92FAT

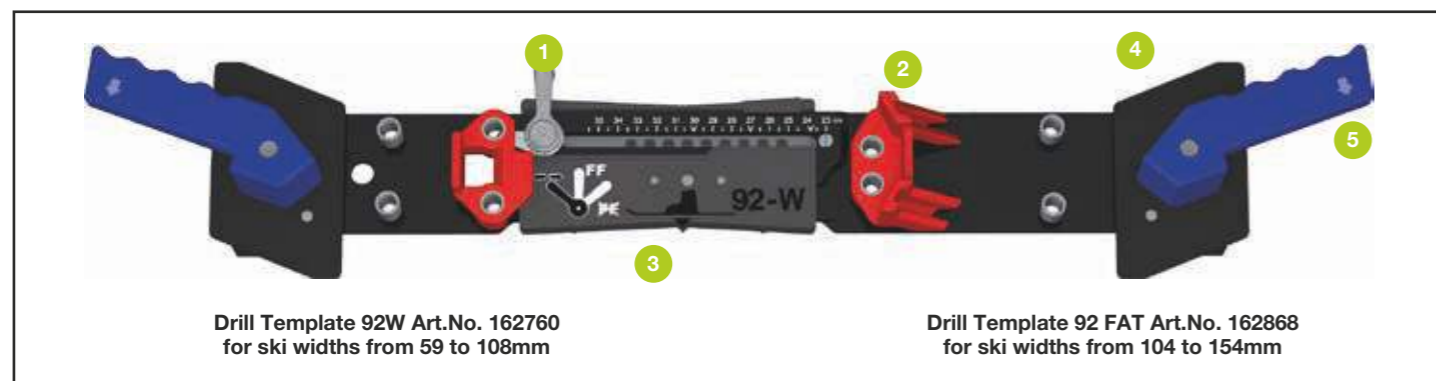

1. COMPATIBILITY

Presently the drill template 92 W & drill template 92 FAT can be used for:

BINDINGS:

ER 18.0 X RD FREEFLEX ST, ER 17.0 FREEFLEX ST, ER 11.0 FREEFLEX, ER 14.0 FREEFLEX, ER 11.0, EL 7.5 GW CA, EL 10.0 GW, ATTACK LYT 11 GW, ATTACK LYT 12 GW

All ELAN adult bindings come with screws with a penetration depth of 8 mm for skis, group G1 & G2.

If recommended by the ski manufacturer use shorter screws with a penetration depth of 6 mm. The junior bindings are delivered with screws with a penetration depth of 6 mm. For mounting junior bindings on plates or on skis, group G1 & G2, replace them by longer screws.

Drill template 92 W can be used for ski widths from 59 mm to 108 mm, whereas the Drill template 92 FAT fits ski widths from 104 mm to 154 mm. For other skis use the template adapter set (Art. No. 162569). With this adapter set, you can mount skis from 45 mm to 132 mm with the standard drill template 92 W, as well as skis from 90 mm to 178 mm with Drill Template 92 FAT.

NOTE: ELAN offers different types of brakes. Refer to the brake overview on page 90 for brake and binding compatibility. The description of the brakes always includes a number and a color-letter code. This number stands for the maximum ski width in the brake area and not in the ski center! The color letter code defines the brake segment.

2. ADJUSTING THE DRILL TEMPLATE

To adjust the template unlock the locking lever (1) by rotating it counter-clockwise to the far left position.

FREEFLEX ST

NOTE: Due to the center piece these bindings are limited to ski boots with sole lengths from 257 to 372 mm. Place the ski boot in the template and push the template together until the stops (2) come against the ski boot sole. Take the boot out of the template. Position the locking lever (1) in the mid position, then open or close the template to the nearest centimeter mark.

FOR TWO-PIECE AND AAAttack BINDINGS

Place the ski boot in the template and push the template together until the stops (2) come against the ski boot sole. Lock the lever to the far right position to prevent length change, and then take the boot out of the template.

3. POSITIONING OF THE DRILL TEMPLATE

Open the clamping jaws (4) of the template by rotating the clamping handles (5) and then place template correctly on the ski, with the boot midsole indicator (3) aligned with the mounting mark on the ski. Be sure the template is evenly seated against the ski's top surface. Release clamping handles to attach the template to the ski. Check the boot midsole mark with template mark. If they are not the same use the boot midsole mark to align the template with the ski mounting mark.

NOTE: Keep in mind that some ski manufacturers do not use the center of boot sole location method. Always follow their instructions.

4. DRILLING THE HOLES

If not otherwise specified by the ski manufacturer, use a 4.1 Ø x 9.0mm drill bit. Use a 4.1 Ø x 7.0 mm drill bit for skis, group G3 & G4. Drill the holes using the appropriate drill bit. If required by the ski manufacturer, tap the holes. After drilling place a drop of ELAN glue in each hole.

5. MOUNTING

5.1. FOR FREEFLEX

Place the pre-assembled heel over the prepared holes (Pict. 1) and tighten the screws in a cross pattern (min. 5 Nm).



Then attach the AFD to the toe and check if the AFD has snapped in, in its specific position (Pict. 2).



Then you have to place the pre-assembled toe over the holes. (Pict.3)



ATTENTION: First you have to tighten the screw in the center – the number has to correspond to the centimeter mark from the template (Pict. 4). To fix it you have to hold the bands together and tighten the screw carefully!

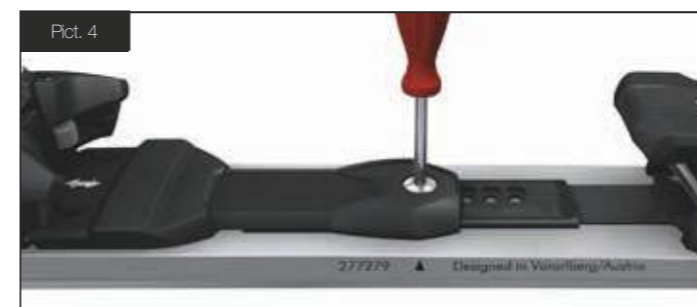

After this align the toe over the holes and fasten the screws in a cross pattern. (Pict 5)



5.2. FOR TWO-PIECE BINDINGS

Hook the brake into heel housing and place the binding over the predrilled holes and tighten the screws in a cross pattern.

5.2.1. BINDINGS with AFS JUNIOR - GW CA models

All binding models marked with CA are suitable for both adult (type A) and children (type C) boots: the innovative mechanical Anti Friction Slider (AFS) automatically adjusts to the boot sole height, compensating A/C standards as well as height differences due to icing up, dirt or boot wear (Pict. 6).



If you want to increase the stability of your junior binding in combination with children (type C) boots, e.g. for junior racing, you can replace the standard AFS with a vertically blocked AFS (Art. No. 163113), which is for children (type C & GW Jr.) boots ONLY. All you have to do is to separate the standard slider from the base plate and you can simply click in the spare slider (Pict. 7).



MOUNTING OF JUNIOR BINDINGS ON PLATES AND ON SKIS, GROUP G1 & G2

For mounting junior bindings on plates or on skis, group G1 & G2, replace the pre-mounted screws by 8 mm penetration depth screws. Only with these screws is the right pullout strength guaranteed.

5.3. FOR Attack BINDINGS

For mounting the toe unit at Attack bindings, place the mounting part over the front 2 drilled holes and tighten the screws. Now slide the toe unit from the rear over the mounting part and fasten the screws. Go on by mounting the heel unit. Hook the brake into heel housing and place the heel unit over the predrilled holes and tighten the screws in a cross pattern. (Pict.8)

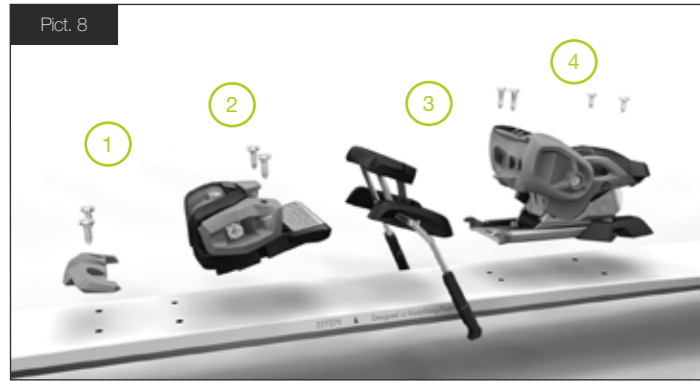

5.3.1. SOLE HEIGHT ADJUSTMENT

ATTENTION! Not necessary for ATTACK LYT GW models due to the automatic sole height adjustment.

The new Attack GW is designed for use with Alpine- (TYPE A) and GripWalk (TYPE A) soles. The Attack 14 MN provides full adjustability for Alpine, Walk (GripWalk) and Touring boots.

	ISO 5355	ISO 23223	ISO 9523
	Alpine Adult (A)	GripWalk (GW)	Touring (T)
Attack 11 LYT GW Attack 11 GW	X	X	O
Attack 17/14 MN	X	X	X

x...suitable o...not suitable

For proper function the height of the AFD must be adjusted to the height of the boot sole. ELAN recommends using the "ELAN boot height adjustment tester" (Art. No. 162983) to get the ideal distance of 0.5 mm between boot and AFD.

For Attack 14 MN please use the A/GW (Alpine and Alpine and GripWalk Type A) and T (Touring) markings for rough adjustment. (Pict. 9)

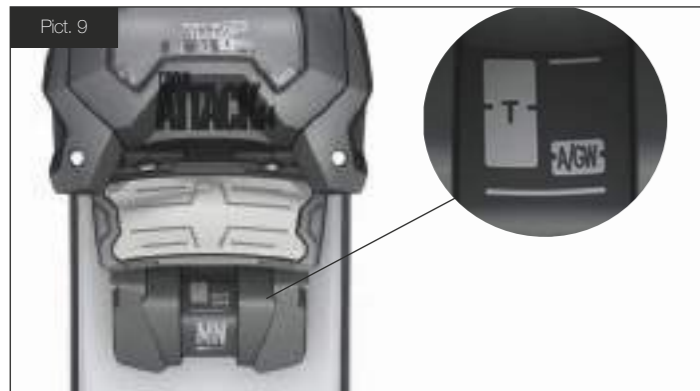

Turning the adjustment screw at the toe moves the AFD up or down. Place the tester on the AFD and enter the boot in the binding. Lift the tip of the boot to take out the play of the toe. (Pict. 10)



Adjust the AFD with the screw in the front so that the tester is still moveable but with a slight resistance. In this case, you reached a gap of 0.5 mm between AFD and the boot (Pict. 11).

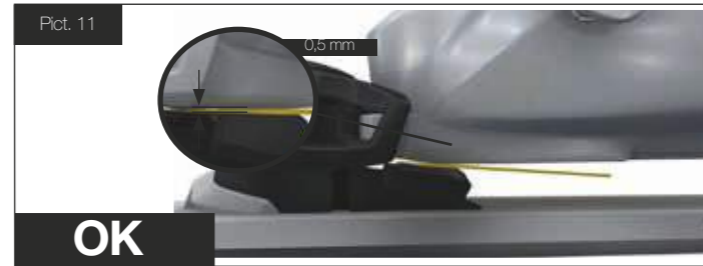

If the tester is not moveable, the gap is smaller than 0.5 mm, if you feel no resistance the gap is more than 0.5 mm. In both cases you need to re-adjust the AFD. (Pict.12)

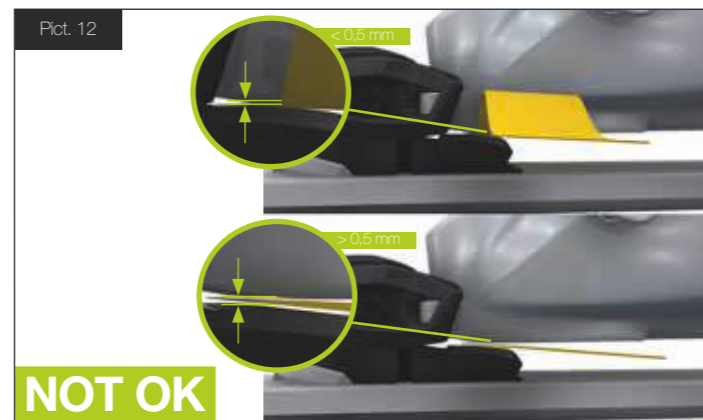

6. ADJUSTING THE RELEASE VALUES

The release values of the toe and heel should be determined by height and body weight (ISO/ASTM) method. Set the binding accordingly with the adjustment screws at heel and toe unit. ELAN recommends adjusting these settings with a manual screwdriver.

Do NOT use a screw shooter!

We also recommend the use of a calibrated testing device and that you keep a written record of whether the system passes or fails (requirement in the US).

NOTE: Release/retention settings above a release moment of 105 NM at the toe and 452 NM at the heel are higher than the international standards recommend and are used solely at the skier's own risk!

7. FORWARD PRESSURE

Make sure that the boot meets international standards and is not damaged. Place the boot in the binding and close it. The indicating pointer should rest within the marked area (Pict. 13)

If not, you have to adjust the forward pressure.



DON'T OPEN THE LENGTH ADJUSTMENT LOCK AS LONG AS A SKI BOOT IS FIXED IN THE BINDING!

Place the ski boot in the open binding and rest the boot heel on the brake pedal. Lift the length adjustment lock with a screwdriver and slide the heel until the heel cup just touches the boot. Lock the length adjustment by pushing it down.

Latch the boot in the binding and check forward pressure again. The toe pincers should not be pressed open and the indicating pointer should rest within the marked area.

8. FUNCTION CHECK

ENTRY/EXIT: Check to make sure that the boot does not catch on the heel hold down lug.

BRAKE: press the brake pedal down by hand. The brake arms must automatically return to the braking position when the pedal is released (Pict.14).



LATERAL ELASTICITY OF THE TOE

Press the boot laterally outward. The binding must re-center the boot easily and quickly from a 15 mm lateral displacement (junior bindings – 10 mm).

9. FINAL CHECK

- Has the proper mounting point been selected?
- Functional brake test passed?
- Have all screws been fastened tightly?
- Was the boot sole height adjusted correctly?
- Has the forward pressure been properly set?
- Are the release values of the toe and heel properly determined and set?
- Is the instruction for use booklet ready to be handed over to the consumer?

MOUNTING

DRILL TEMPLATE AMBITION



1. COMPATIBILITY

Presently the drill template AMBITION can be used for:

BINDINGS:
AMBITION 12 MN

All Ambition bindings come with 8 mm penetration screws and can be used with skis of groups G1 & G2. If recommended by the ski manufacturer use shorter screws with a penetration depth of 6 mm. Therefore use the spare part "Ambition Screw Set - G3 & G4 (6 mm) Art. No. 163055".

Drill template Ambition can be used for ski widths from 75 to 125 mm. For other skis use the template adapter set (Art. No. 162569). With this adapter set, skis from 61 to 149 mm can be mounted. Alternatively, the use of the attached plastic foil template is also an option.

NOTE: ELAN offers different types of brakes. Refer to the brake overview on page 90 for brake and binding compatibility. The description of the brakes always includes a number and a color-letter code. This number stands for the maximum ski width in the brake area and not in the ski center! The color letter code defines the brake segment.

2. POSITIONING OF THE TEMPLATE

There are two ways to mount Ambition bindings. Either with the solid jig (Art. No. 163000) or with the plastic foil template (Art.No. 163011), which is included in the packaging of each binding. We will show both procedures. First of all, make sure that the boot is satisfying the international standards and has no functional damage. Determine the boot sole length with the rental caliper (Art. No. 162617).



NOTE: Keep in mind that some ski manufacturers do not use the center of boot sole location method. Always follow their instructions.

2.1. DRILL TEMPLATE

Adjust the boot sole length on the template - open it by pulling the locking lever (1) to the left position. Slide the template to the right length position and push the locking lever (1) to middle position. Slide the template to closest centimeter mark, until it snaps into position.

Please use following length markings for Rental versions:

Version	Length position
Ambition Rental	35 cm

Place the template on the ski and center the jig. Therefore open the clamping jaws (4) by rotating the clamping handles (2) and then place the template on the ski. Select the right midsole indicator (3) on the template (Black for RETAIL or Red for RENTAL version), align the indicator with the midsole mounting mark on the ski.



Release the handles and ensure that the template is evenly seated against the ski's top surface. Select the right holes! The front holes are identical for all versions (Retail and Rental - red-silver bushings). You just have to select the right bushings for the rear holes:

Version	Color of bushings/Indicators
Ambition Retail	silver
Ambition Rental	red

2.2. PLASTIC FOIL TEMPLATE

Follow the same procedure with the plastic foil template - place it on the ski, align the correct boot mid sole mark with the ski mounting mark. Fix it with a sticky tape and ensure that the template is centered and evenly seated against the ski's top surface.



After that, you can mark the correct positions with a punch (Pict. 18) for front and rear position. Remove the plastic foil template from the ski surface.



3. DRILLING THE HOLES

If not otherwise specified by the ski manufacturer, use a 4.1 Ø x 9 mm drill bit for the toe and the heel track (8 holes) if required by the ski manufacturer, tap the holes. After drilling, place a drop of glue into the holes. It lubricates the screws and seals the holes.

4. MOUNTING

Just start with mounting the heel unit of the binding depending on the version.

4.1. HEEL UNIT

4.1.1. RETAIL VERSION - HEEL UNIT

Place the heel unit over the rear holes and fasten all screws in a cross pattern and continue at 4.2. (Pict. 19)



4.1.2. RENTAL VERSION - HEEL UNIT

Start with placing the Demo Track over the holes and fasten all screws in a cross pattern. Use the screws provided with the binding. (Pict.20)

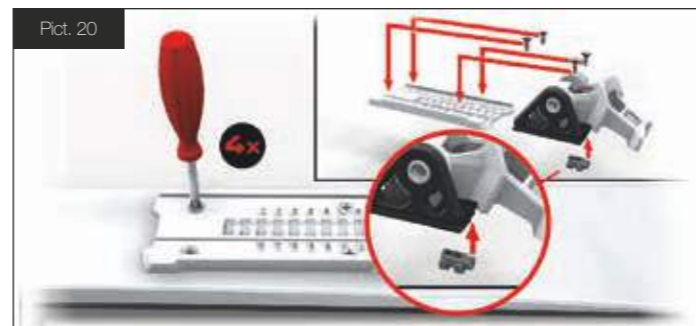

Insert the screw in the bottom side of the heel unit, and slide the whole unit to the closest mounting position on demo track and fix it with the screw.



4.2. MOUNTING OF THE TOE UNIT

If you are mounting the RENTAL version, the dampener has to be changed (white dampener out and black one in).

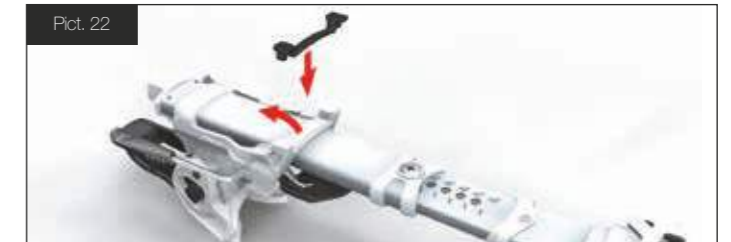

From now on the mounting is the same in RETAIL and RENTAL version. Start with the Adjustment of the telescopic tube to the closest mounting position and fix it with the screw.



Close the ascender lock and slide the binding into the closed position in all versions.

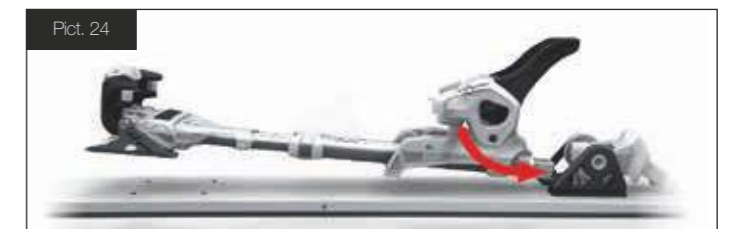

Place the toe unit assembly over the front holes and fasten the two front screws.



Open the ascender lock and tighten the other two screws of the toe unit.

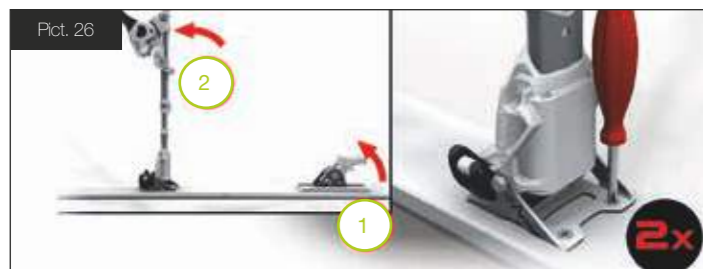

!!!ATTENTION!!! Ambition bindings are sold without brakes. Please choose the proper brake width for your ski and mount it on the binding. You can also use it to ride and hike with the appropriate powder straps. It is required to use one of these options (in reference to ISO 11088)!!

A.No	Spareparts
DF163098	Brake Ambition 85 black [C]
DF163099	Brake Ambition 95 black [C]
DF163100	Brake Ambition 105 black [C]
DF163101	Brake Ambition 125 black [C]
DF162981	AAA-Series Powder Strap (1 pair)

4.3 MOUNTING OF THE BRAKES

Remove the heel base plate – therefore remove both screws completely. Pop out the plate with a flat screwdriver.



Take the Ambition brake arm, press it together and clap the brake pedal to a horizontal position. First click right then left side into place.



Check the right position of the brake.



Place the brake to its position on the heel unit, push the plate to lock on binding. Fix the plate with the two screws. Ready!!!

5. SOLE HEIGHT ADJUSTMENT

The Ambition is designed to accommodate both type of boots - Alpine ski boots (ISO 5355 TYPE A), GripWalk ski boots (ISO 23223 TYPE A) and Touring boots (ISO 9523). For proper function the height of the toe unit must be adjusted to the height of the boot sole. ELAN recommends to use the "boot height adjustment tester" (Art. No. 162983) to get the ideal distance of 0.5 mm between boot and AFS.

Turning the adjustment screw at the toe moves the unit up or down. Place the tester on the AFS and enter the boot in the binding. Lift the tip of the boot to take out the play of the toe.

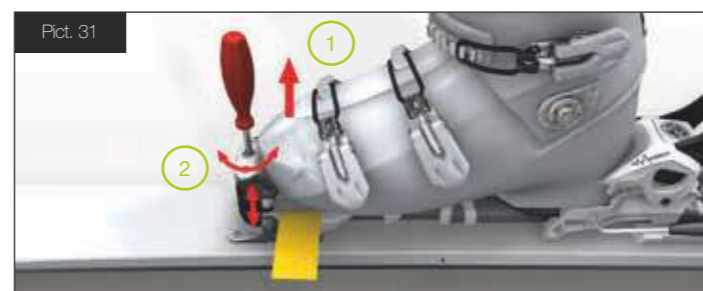

Adjust the AFS with the screw in the front so that the tester is still moveable but with a slight resistance. In this case, you reached a gap of 0.5 mm between AFS and the boot.

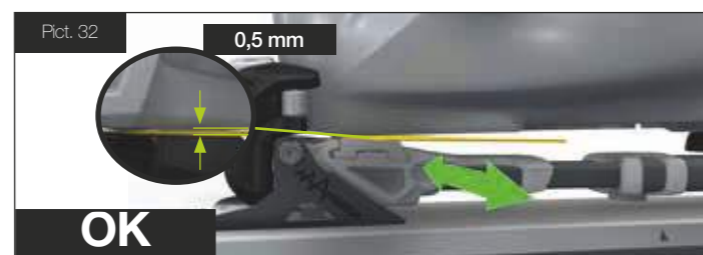

If the tester is not moveable, the gap is smaller than 0.5 mm, if you feel no resistance the gap is more than 0.5 mm. In both cases you need to re-adjust the AFS.

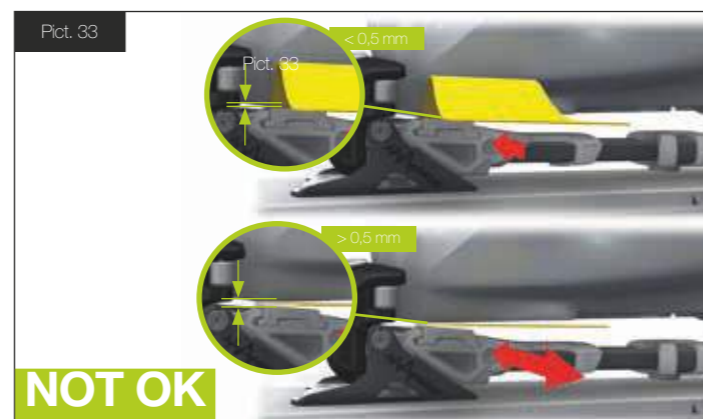

6. ADJUSTMENT OF THE RELEASE VALUES

The release values of the toe and heel should be determined by height and body weight (ISO/ASTM) method. Set the binding accordingly with the adjustment screws at heel and toe unit. ELAN recommends adjusting these settings with a manual screwdriver. Do NOT use a screw shooter. We also recommend the use of a calibrated testing device and that you keep a written record of whether the system passes or fails (requirement in the US).

NOTE: Release/ Retention settings above a release moment of 105 NM at the toe and 452 NM at the heel are higher than the international standards recommend and are used solely at the skier's own risk!

7. FORWARD PRESSURE

Check the forward pressure, by placing a boot into the binding. If you have followed all mounting steps correctly, the indicator and the heel housing should be on a flat surface.

If you have too much or not enough forward pressure, check the settings and if necessary re-adjust the heel.



8. FUNCTION CHECK

Check the function of the heel. Make sure that the boot does not catch on the heel during entry and exit. Check the brake function (Pict. 42) by pressing down the brake pedal (1) by hand. The brake arms (2) must open to the braking position when the brake pedal is released. Check the elasticity and retention of the toe by pushing the boot inward and outward. The binding must recenter the boot easily and quickly from a 15 mm lateral displacement.



9. ADDITIONAL EQUIPMENT AND SPARE PARTS FOR AMBITION:

9.1. AMBITION CRAMPONS

ELAN is offering additional crampons for AMBITON Bindings. Use the

crampons in icy and hard snow conditions to provide safe climbing and a secure stance in any situation. Be sure to use the right width - 90 mm (Art.No. 163006), 105 mm (Art.No. 163007) or 120 mm (Art.No. 163008).

MOUNTING: Open the climbing aid and swing open the binding. Take the crampon and slide it to the fixing- position on the bottom of the telescopic tube. Consider the right position as shown in pict. 36. Lock the crampon with the lever- ready!



To remove just unlock the crampon with the lever and take off the crampon from the telescopic tube (Pict. 36).

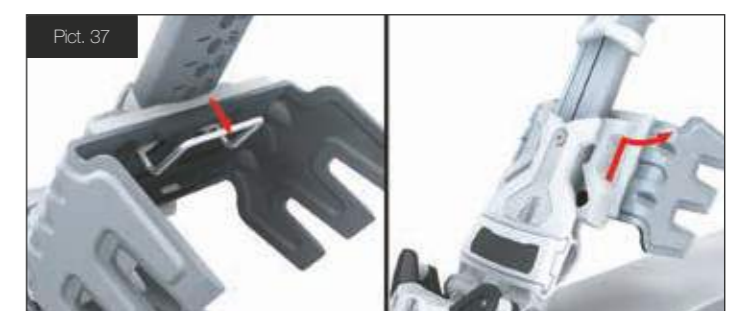

9.2. A-SERIES POWDER STRAP

Instead of brakes it is also possible to use the A-Series powder strap for riding and hiking. At Ambition bindings it is required to use either brakes or powder strap! To fix the strap on your binding take the hanger from the strap and fix it on the heel lever as shown in pict. 38.



Fix the strap with the Velcro fastener on your leg and use the carabiner to connect strap and hanger again.

10. FINAL CHECK

- Has the proper mounting point selected?
- Brake or Powder Strap mounted?
- Functional brake test passed?
- Are all screws fastened tightly?
- Was the boot sole height adjusted correctly?
- Is the forward pressure properly adjusted?
- Are the release values of the toe and heel properly determined and set?
- Is the instruction for use booklet ready to be handed over to the consumer?

MOUNTING

DRILL TEMPLATE 94W

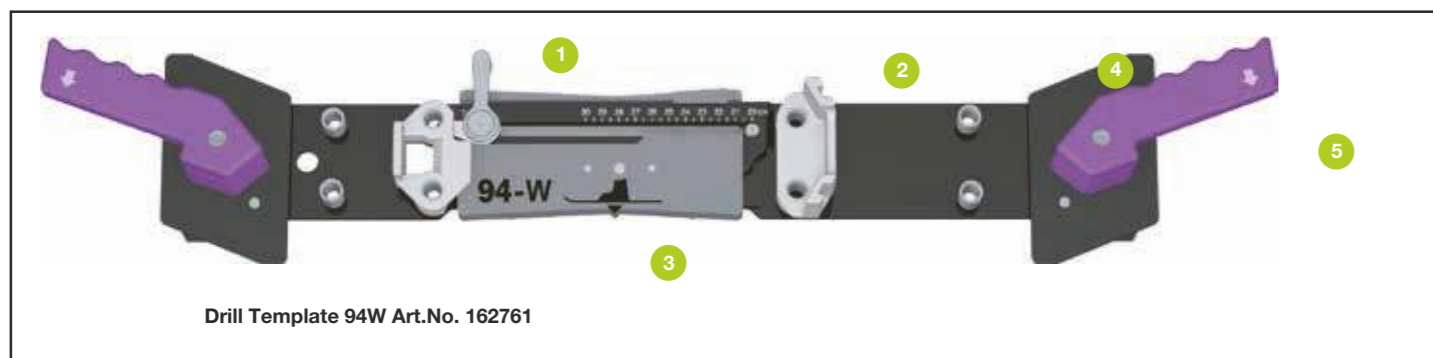

1. COMPATIBILITY

Presently the drill template 94 W can be used for:

BINDINGS:
EL 4.5 GW CA

Drill template 94 W can be used for ski widths from 59 mm to 108 mm. For other skis use the template adapter set (Art. No. 162569).

The EL 4.5 GW CA binding comes with 6 mm penetration depth screws and can be used for skis-group G3 & G4. The standard brake, the SX KID BRAKE 80 [K], can be used for skis up to 80 mm.

NOTE: ELAN offers different types of brakes. Refer to the brake overview on page 90 for brake and binding compatibility.

The description of the brakes always includes a number and a color-letter code. This number stands for the maximum ski width in the brake area and not in the ski center! The color letter code defines the brake segment.

2. ADJUSTING THE DRILL TEMPLATE

Unlock the locking lever (1) by rotating it counter-clockwise. Place the template on the ski. Place the ski boot in the template. Push the template together until the stops are against the sole (2). Lock the lever (1) to prevent length change and take the boot out of the template.

3. POSITIONING OF THE DRILL TEMPLATE

Align the boot midsole indicator (3) with the midsole mounting mark on the ski. Be sure the template is evenly seated against the ski's top surface. Release clamping handles to attach the template to the ski. Check the boot midsole mark with template mark. If they are not the same use the boot midsole mark to align the template with the ski mounting mark.

NOTE: Some ski manufacturers do not use the center of boot sole location method. Always follow the ski manufacturer's instructions.

4. DRILLING THE HOLES

If not otherwise specified by the ski manufacturer, use a 4.1 Ø x 7.0 mm drill bit, which is the right bit for skis, group G3 & G4. Drill the holes using an appropriate drill. If required by the ski manufacturer, tap the holes. Place a drop of glue into the holes. It lubricates the screws and seals the ski (Pict. 39).



5. MOUNTING

Place the toe unit over the holes and fasten the screws in a cross-pattern. Then do the same for the heel (Pict. 40).

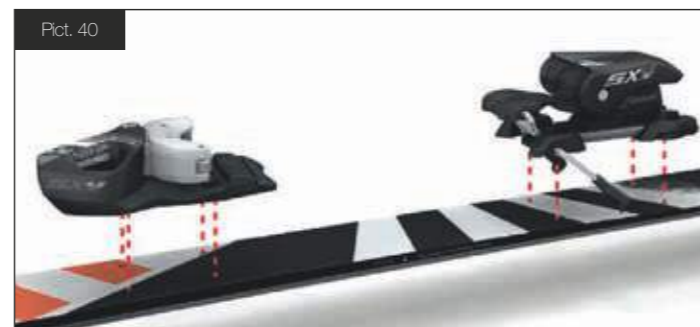

6. ADJUSTMENT

Use the ELAN Rental Caliper to check and make sure that the boot meets international standards and is not damaged.



7. FORWARD PRESSURE

Place the boot in the binding and close it. The indicating pointer should rest within the marked area (Pict. 42), if not you have to adjust the forward pressure.

DON'T OPEN THE LENGTH ADJUSTMENT LOCK AS LONG AS A SKI BOOT IS FIXED IN THE BINDING.

Place the ski boot in the open binding and rest the boot heel on the brake pedal. Lift the length adjustment lock (1) with a screwdriver and slide the heel until the heel cup just touches the boot. Lock the length adjustment by pushing it down. Latch the boot in the binding and check forward pressure again. The toe pincers should not be pressed open and the indicating pointer should rest within the marked area (Pict. 42).



AFS GW JUNIOR

The SX Junior and SX Kid lines are suitable for both Adult (ISO 5355 TYPE A) and Children (ISO 5355 TYPE C) boots as well as GripWalk (ISO 23223 TYPE A) and GripWalk Junior (ISO 23223 TYPE C) boots: the innovative mechanical Anti Friction Slider (AFS GW Jr.) automatically adjusts to the boot sole height, A/C standards, GripWalk standards as well as height differences due to icing up, dirt or boot wear (Pict. 43).



If you want to increase the stability of your junior binding in combination with children (type C) boots, you can replace the standard AFS with a vertically blocked AFS (Art. No. 163113), which is for children (type C) boots and GripWalk Junior boots ONLY. All you have to do is to separate the standard slider from the base plate. Afterwards you can simply click in the spare slider. All you have to do is to separate the standard slider from the base plate. Afterwards you can simply click in the spare slider. (Pict. 44).

ADJUSTING THE RELEASE VALUES

The release values of the toe and heel should be determined by height and body weight (ISO/ASTM) method.

Set the binding accordingly with the adjustment screws at heel and toe unit. ELAN recommends adjusting these settings with a manual screwdriver. Do NOT use a screw shooter! We also recommend the use of a calibrated testing device and that you keep a written record of whether the system passes or fails (requirement in the US).

8. FUNCTION CHECK

ENTRY/EXIT: Check to make sure that the boot does not catch on the heel hold down lug.

BRAKE: Press the brake pedal (1) down by hand. The brake arms (2) must automatically return to the braking position when the treadle is released (Pict. 45).



LATERAL ELASTICITY OF THE TOE

Press the boot laterally outward. The binding must re-center the boot easily and quickly from a 10 mm lateral displacement.

9. FINAL CHECK

- Has the proper mounting point been selected?
- Functional brake test passed?
- Have all screws been fastened tightly?
- Has the forward pressure been properly set?
- Are the release values of the toe and heel properly determined and set?
- Is the instruction for use booklet ready to be handed over to the consumer?

MOUNTING

DRILL TEMPLATE ATTACK DEMO



1. COMPATIBILITY

Presently the drill template Attack DEMO can be used for:

BINDINGS:
ATTACK 14 MN DEMO, ATTACK LYT 11 GW DEMO

All Attack 11 MN DEMO bindings come with 8 mm penetration screws and can be used with skis of groups G1 & G2. If recommended by the ski manufacturer use shorter screws with a penetration depth of 6 mm. Therefore use the spare part "Screw Set Attack 11/14 MN Demo – G3 & G4 (6 mm)" (Art. No.163091).

Drill template Attack Demo can be used for ski widths from 75 to 125 mm. For other ski widths please use the template adapter set (Art. No. 162569). With this adapter set skis from 61 to 149 mm can be mounted.

NOTE: ELAN offers different types of brakes. Refer to the brake overview on page 90 for brake and binding compatibility.

The description of the brakes always includes a number and a color-letter code. This number stands for the maximum ski width in the brake area and not in the ski center! The color letter code defines the brake segment.

2. POSITIONING OF THE TEMPLATE

There are two ways to mount Attack Demo bindings. Either with the solid jig (A.No. 163009) or with the plastic foil template (this is included in the packaging of each binding and also available as a spare part A.No. 163015). We will show both procedures.

NOTE: Keep in mind that some ski manufacturers do not use the center of boot sole location method. Always follow the ski manufacturer's instructions.

2.1. DRILL TEMPLATE

Open the clamping jaws (2) by rotating the clamping handles (1) and then place the template on the ski. Align the boot midsole indicator (3) with the midsole mounting mark on the ski. Release the handles and ensure that the template is evenly seated against the ski's top surface.



2.2. PLASTIC FOIL TEMPLATE

Align the boot midsole indicator with the midsole mounting mark on the ski. Fix it with a sticky tape and ensure that the template is centered and evenly seated against the ski's top surface. After that you can mark the indicators (8x) with punch and remove the plastic foil template from the ski surface.

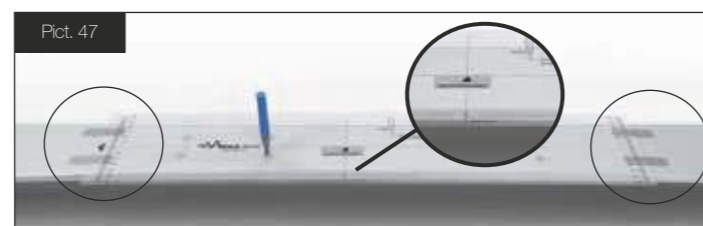

3. DRILLING THE HOLES

If not otherwise specified by the ski manufacturer use a 4.1 Ø x 9 mm drill bit for all holes (8x) for the toe and the heel track.



After drilling place a drop of glue into the holes. It lubricates the screws and seals the holes.

4. MOUNTING

First of all, make sure that the boot is satisfying the international standards and has no functional damage. Determine the boot sole length with the rental caliper (A.No. 162 617).



Go on with placing the toe track over the holes and fasten all screws in a cross pattern.



Open the one-touch lever and slide the toe unit from the front on the track and lock it at the appropriate boot sole marking.



Now you can mount the heel unit. Place the heel track over the holes and fasten all screws in a cross pattern.



Now hook the brake into the heel, open the one touch lever, slide the heel unit from the back to the track and lock it at the appropriate boot sole marking.



5. SOLE HEIGHT ADJUSTMENT

ATTENTION! Not necessary for ATTACK LYT GW and PROTECTOR ATTACK LYT GW models due to the automatic sole height adjustment.

The new Attack MN DEMO provides full adjustability for Alpine ski boots (ISO 5355 TYPE A), GripWalk ski boots (ISO 23223 TYPE A) and Touring boots (ISO 9523).

	ISO 5355	ISO 23223	ISO 9523
	Alpine Adult (A)	GripWalk (GW)	Touring (T)
Attack MN DEMO	X	X	X
ATTACK LYT GW DEMO	X	X	O

x...suitable o...not suitable

For proper function the height of the AFS must be adjusted to the height of the boot sole. ELAN recommends using the "boot height adjustment tester" (Art. No. 162983) to get the ideal distance of 0.5 mm between boot and AFS. Turning the adjustment screw at the toe moves the AFS up or down.

Place the tester on the AFS and enter the boot in the binding. Lift the tip of the boot to take out the play of the toe. Adjust the AFS with the screw in the front so that the tester is still moveable but with a slight resistance.

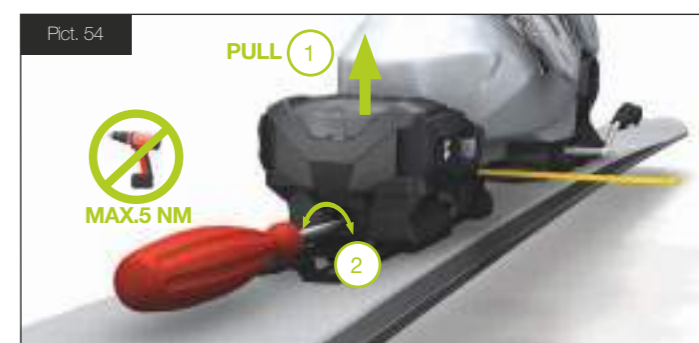

In this case, you reach a gap of 0.5mm between AFS and the boot.

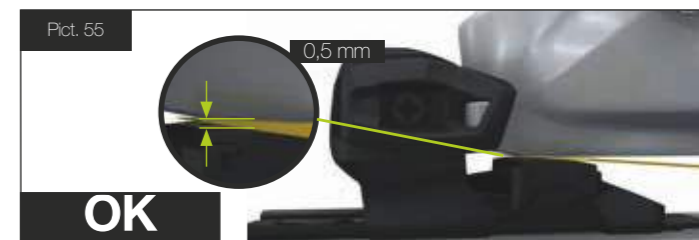

If the tester is not moveable, the gap is smaller than 0,5 mm, if you feel no resistance the gap is more than 0.5 mm. In both cases you need to re-adjust the AFS.

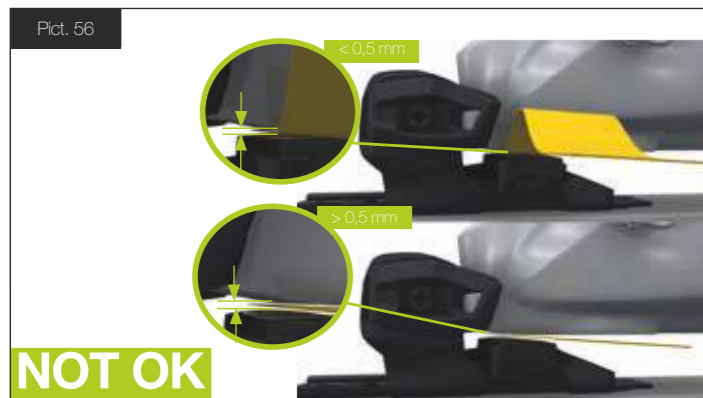

6. ADJUSTMENT OF THE RELEASE VALUES

The release values at toe and heel should be determined by height and body weight (ISO/ASTM) method. Set the binding accordingly with the adjustment screws.

We recommend the use of a calibrated testing device and that you keep a written record of whether the system passes or fails (requirement in the US).

NOTE: Release/ Retention settings above a release moment of 105 NM at the toe and 452 NM at the heel are higher than the international standards recommend and are used solely at the skier's own risk!

7. FORWARD PRESSURE

Check the forward pressure, by placing a boot into the binding. If you have followed all mounting steps correctly, the indicator should rest in the marked area and you are ready to go.



If you have too much or not enough forward pressure, check the settings and if necessary re-adjust the heel. Then close the lever and check the forward pressure again. Now it should be okay!

8. FUNCTION CHECK

Check the function of the heel. Make sure that the boot does not catch on the heel during entry and exit. Check the brake function by pressing down the brake pedal (1) by hand. The brake arms (2) must open to the braking position when the brake pedal is released.

Check the elasticity and retention of the toe by pushing the boot inward and outward. The binding must recenter the boot easily and quickly from a 15 mm lateral displacement.



9. FINAL CHECK

- Was the proper mounting point selected?
- Did it pass the functional brake test?
- Are all screws fastened tightly?
- Was the boot sole height adjusted correctly?
- Is the forward pressure properly adjusted?
- Are the release values of the toe and heel properly determined and set?
- Is the instruction for use booklet ready to be handed over to the consumer?
- Are the release values of the lateral heel release properly determined and set? (Protector)

MOUNTING DRILL TEMPLATE BASES & PLATES

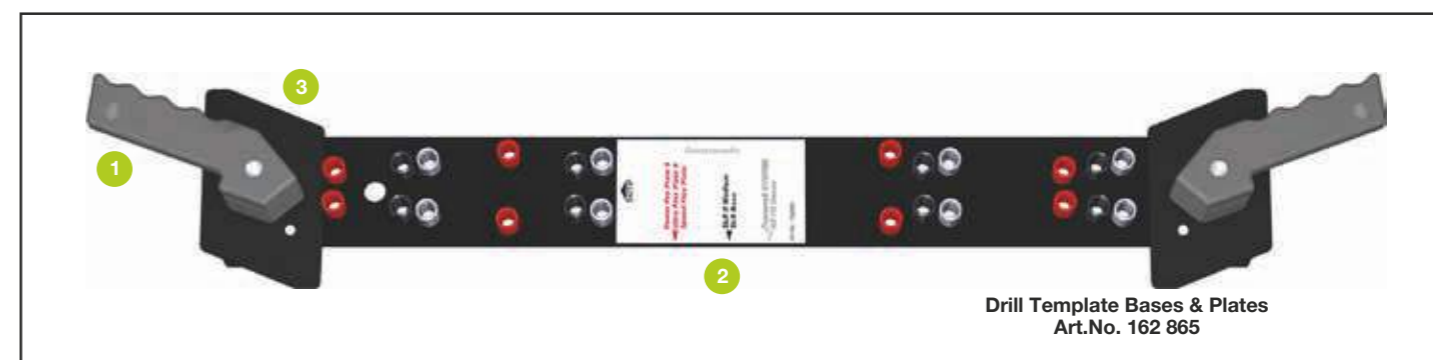

1. COMPATIBILITY

Presently the drill template Bases & Plates can be used for:

PLATES:
EP 9.0, EP 9.0+, Twin PR Base

Drill template BASES & PLATES is for mounting of all types of plates and bases, except the RACEPLATES. All bases and plates come with 8 mm penetration depth screws. For the SUPERLITERAIL bases the right screws has to be used according to the ski specification. Drill template BASES & PLATES can be used for ski widths from 59 to 108 mm. For other skis use the template adapter set (Art. No. 162569). With this adapter set skis from 45 to 132 mm can be mounted. The following chart shows which ELAN bases and plates are suitable for the different ski-groups (G1-G4).

Model	G1	G2	G3	G4
TWIN PR BASE	x	x	x	o
POWERPRO PLATE 9	x	x	x	o

x ...suitable o ...not suitable

If bases and plates are mounted on other ski groups, the penetration depth and the torque moment of the screws have to be verified.

2. POSITIONING OF THE DRILL TEMPLATE

Open the clamping jaws (3) by rotating the clamping handles (1) and then place the template on the ski. Align the boot midsole indicator (2) for the appropriate model with the midsole mounting mark on the ski. Be sure the template is evenly seated against the ski's top surface. Release clamping handles.

NOTE: Keep in mind that some ski manufacturers do not use the center of boot sole location method. Always follow the ski manufacturer's instructions.

3. DRILLING THE HOLES

If not otherwise specified by the ski manufacturer, for all bases use a 4.1 Ø x 9.0 mm drill bit for skis, groups G1 & G2. For skis of, groups G3 & G4, use a 4.1 Ø x 7.0mm drill bit.

DRILL THROUGH THE APPROPRIATE BUSHINGS

Model	Color of bushings/indicatorS
EP 9.0 EP 9.0+	red
TWIN PR BASE	white

After drilling place a drop of glue into the holes. It lubricates the screws and seals the holes.

4. PLATES

4.1. MOUNTING - PLATES

The compatible binding-plate combinations can be found in the compatibility chart (see next page). Place the front part of the plate over the holes and fasten the screws. Then place the back part over the holes and fasten the screws.



4.2. MOUNTING - BINDING ON PLATES

For mounting junior bindings on PLATES, you have to replace the pre-mounted screws by screws of 8 mm penetration depth. The right pullout strength can only be ensured with these screws.

NOTE: Use only the pre-drilled holes for installation – do not drill holes into the plate to mount bindings of other manufacturers.

Determine the boot sole length with the Rental boot caliper and place the binding on the plate corresponding with the appropriate printed

length markings. Mount the binding in accordance with the procedures in this manual.

MOUNTING BINDINGS ON RAISED PLATFORMS:

Please note the ELAN brake-matrix on the next page. There you will find a classification of all our brakes depending on stand height and weight. A brake is permitted, if the combination of stand height and weight hits the sector under the relevant curve. If not the brake has to be changed by a stronger one of a higher category.

At all current ELAN ski sets with ELAN binding- plate-systems the included brakes fit these requirements. If you are combining ELAN bindings and plates with product of other manufacturer please check the technical requirements of the ski – plate – binding – combination at the ELAN brake matrix on next page. There you will find out, if the desired combination of ski- plate-binding is accepted.

FOLLOW THE PROCEDURE BELOW:

1. Add the weight of the components you want to mount (ski + plate + binding).
2. Add the thickness of the components you want to mount (ski + plate + binding).
3. Find the value on the vertical axis which corresponds to the sum of the addition for the stand height.
4. Follow the horizontal axis on the matrix to the right until you find the value which corresponds to the total weight on the horizontal axis.

5. Use the lists at chapter "Technical Information", determine the standard brakes of the binding and based

6. If the point of intersection of the weight and stand height lies below the respective curve, the brake will work properly.
7. If the point of intersection lies above the curve the brake must be replaced with the next stronger one.
8. If the point of intersection lies above the highest curve this combination of ski + binding + plate is not recommended. In this case, you have the following possibilities to come within the permitted range:

- a) Reduce the total thickness through:
 - a thinner plate
 - A binding with less stand height
- b) Reduce the total weight to
 - a lighter plate
 - A binding with less weight
 - a lighter ski
- c) Use a combination of a) + b)

Have a look at all technical specifications about ELAN bindings and plates in chapter "Technical Information" – this will help you in finding an accepted combination.

4.3 ELAN BINDING-PLATE COORDINATION 2024/25

Height: Mounting Range: Mounting Range (SX):	Raceplate WCR 14, Raceplate WCR 14 Short	Raceplate Evo 14	EP 11.5 DUO 11,5mm 238-342mm 241-353mm
BINDING	STAND HEIGHT [mm]		
ER 18.0 X RD FREEFLEX ST	31.0	31.0	x
ER 17.0 FreeFlex ST	31.0	31.0	28.5.
ER 14.0 FreeFlex ST ER 11.0 FreeFlex ST ER 11.0	35.0	35.0	32.5
EL 10.0 GW	35.0	35.0	32.5
ESP 10.0 GW	45.0*	45.0*	x
ESR 10.0 GW	36.0*	36.0*	x

x ...not suitable

*if plate is mounted in silver position (290-350mm)

4.4. ELAN BRAKE MATRIX 2024/25

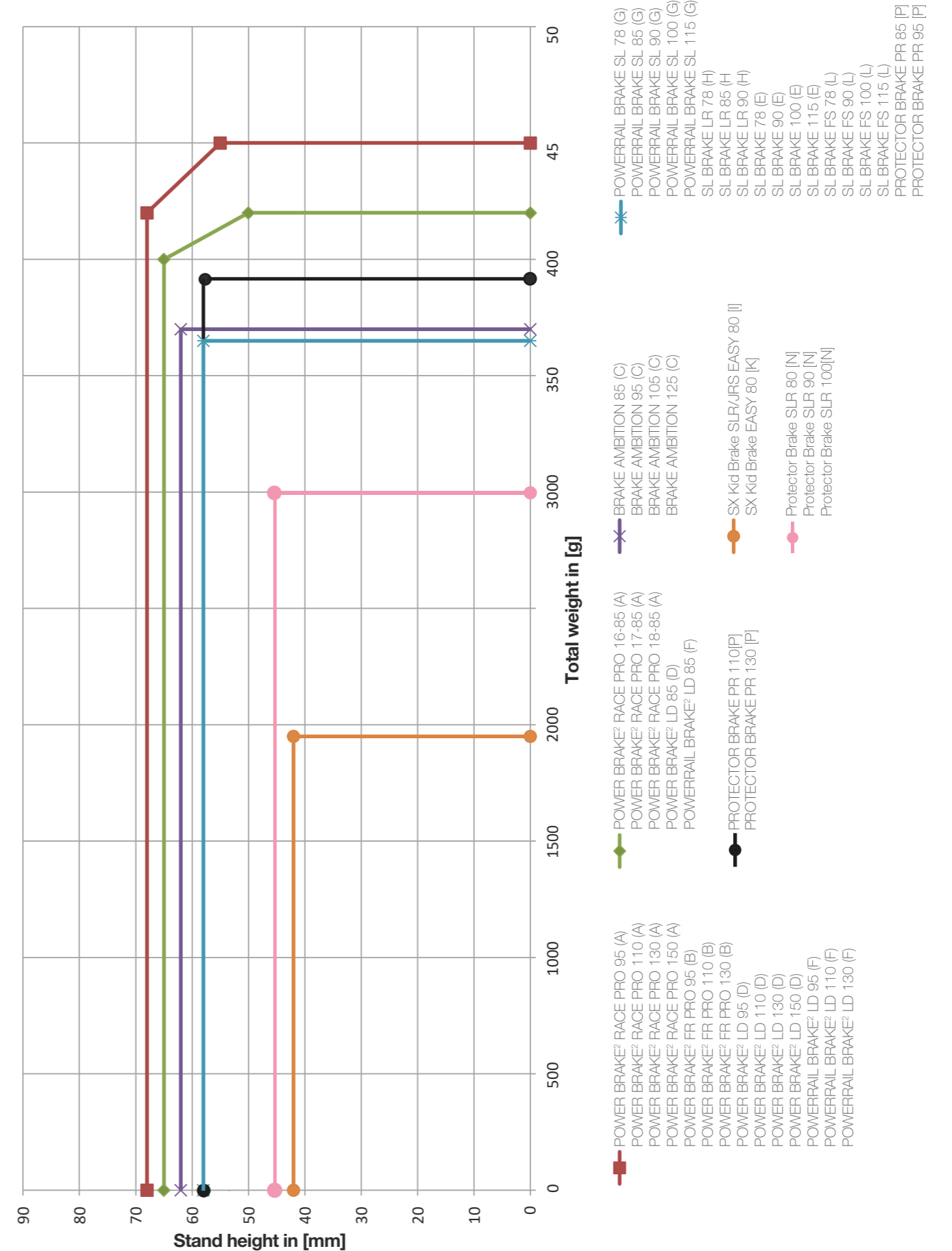

5. ADJUSTMENT OF THE RELEASE VALUES

The release values of the toe and heel should be determined by height and body weight (ISO/ASTM) method. Set the binding accordingly with the adjustment screws at heel and toe unit. ELAN recommends adjusting these settings with a manual screwdriver. Do NOT use a screw shooter. We also recommend the use of a calibrated testing device and that you keep a written record of whether the system passes or fails (requirement in the US).

NOTE: Release/Retention settings above a release moment of 105 NM at the toe and 452 NM at the heel are higher than the international standards recommend and are used solely at the skier's own risk!

5.1. ADJUSTMENT OF LATERAL HEEL RELEASE

For PROTECTOR bindings, in addition to the toes and heels, set the release/retention setting of the lateral heel release according to the initial indicator setting. The adjustment screw for the lateral heel release is indicated on the product by a red "ADJUSTMENT" symbol around the screw head.



NOTE: The settings for the lateral heel release can differ from the final indicator settings on the toes and the heels, as it always remains at the initial indicator settings! No further testing or adjustment is necessary. ELAN guarantees optimal functioning to keep you safe!

6. FORWARD PRESSURE

Finally, check the forward pressure, by placing a boot into the binding. If you have followed all steps correctly, the indicator should rest in the marked area.



If you have too much or not enough forward pressure, check the settings and if necessary, adjust slightly at the heel and the toe. Then close the levers and check the forward pressure again. Now it should be okay.

ADAPTATION:

Once the binding is mounted onto a ski it is very easy to adjust it to another boot sole length. Just open the levers and slide toe and heel to the desired length mark. Finally close the levers and check forward pressure as described before.

7. FUNCTION CHECK

Check the function of the heel. Make sure that the boot does not catch on the heel during entry and exit. Check the brake function by pressing down the brake pedal (1) by hand. The brake arms (2) must open to the braking position when the brake pedal is released (Pict.62).



Check the elasticity and retention of the toe by pushing the boot inward and outward. The binding must recenter the boot easily and quickly from a 15 mm lateral displacement.

8. FINAL CHECK

- Is the proper mounting point selected?
- Functional brake test passed?
- Have all screws been fastened tightly?
- Is the forward pressure properly adjusted?
- Are the release values of toe and heel properly determined and set?
- Is the Instruction for use booklet ready to be handed over to the customer?
- Are the release values of the lateral heel release properly determined and set? (Protector)

NOTES:

MOUNTING

DRILL TEMPLATE RACEPLATE WCR

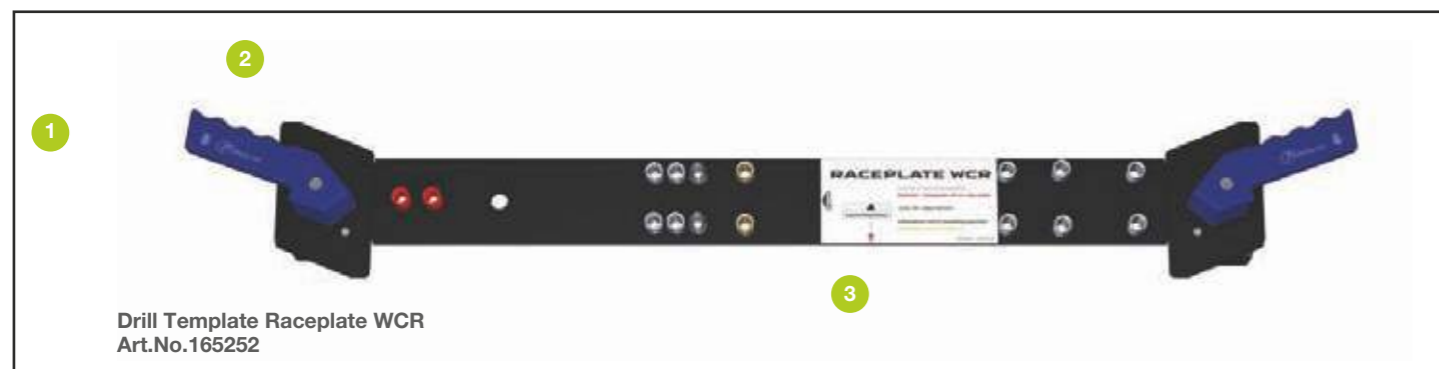

1. COMPATIBILITY

Presently the drill template Raceplate WCR can be used for:

PLATES:
RACEPLATE WCR

The Raceplate WCR comes with 8 mm penetration screws and can be used with skis, groups G1 & G2. Drill template Raceplate WCR can be used for ski widths from 59 to 108 mm. For other skis use the template adapter set (Art. No. 162569). With this adapter set ski widths from 45 to 132 mm can be mounted.

2. POSITIONING THE DRILL TEMPLATE

Open the clamping jaws (2) by rotating the clamping handles (1) and then place template on the ski. Align the boot mid-sole indicator (3) with the midsole mounting mark on the ski. Be sure the template is evenly seated against the ski's top surface. Release clamping handles (1) and attach the template firmly to the ski.

NOTE: Some ski manufactures do not use the center of boot sole location method. Always follow the ski manufacturer's instructions.

3. DRILLING THE HOLES

If not otherwise specified by the ski manufacturer, use a 4.1 Ø x 9.0 mm drill bit for skis, groups G1 & G2. Use the silver bushings for the standard mounting position (Pict. 63). Use the red bushings only if you want to mount the optional logo plate or the interchangeable dampener kit (Art. No. 163081).

If required by the ski manufacturer, tap the hole. After drilling place a drop of ELAN glue into the holes. It lubricates the screws and seals the holes.



4. MOUNTING

4.1. MOUNTING - PLATE

Place the mounting bracket onto the prepared holes and fasten the screws in a cross pattern (Pict 64)

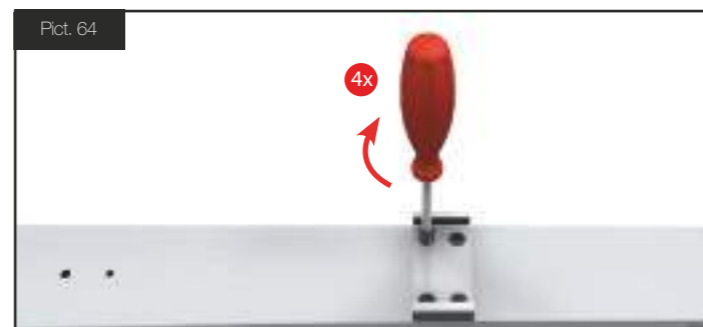

Slide in the plate until the midsole indicator aligns with the midsole mounting mark on the ski (Pict. 65)

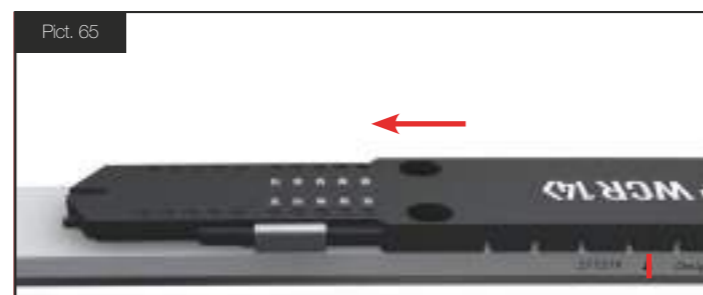

Check if the holes align with the prepared holes in the ski and fasten the screws as shown below (Pict. 66).

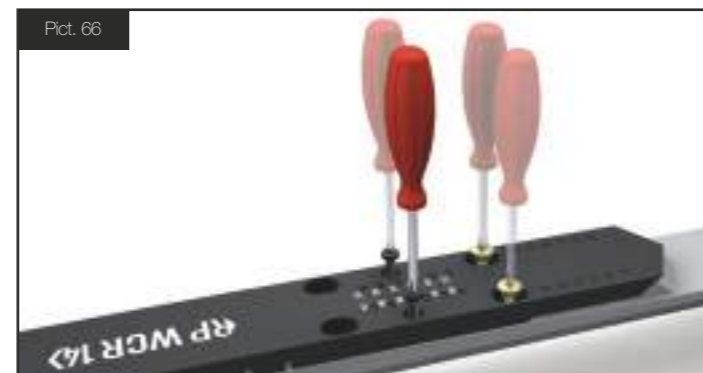

Slide on the cap and place the logo plate (optional) onto the prepared holes and fasten the screws (Pict. 67).

To fasten the fixing screw of the cap it is not recommended to use a screw shooter as it is possible to overturn the screw (Pict.68).



4.2. MOUNTING - BINDING

Use only the pre-drilled holes for installation – do not drill holes into the plate to mount bindings of other manufacturers. Determine the boot sole length with the ELAN Rental boot caliper and place the binding on the plate corresponding with the appropriate printed length markings. Mount the binding in accordance with the procedures in this manual.

5. FINAL CHECK

- Have the proper mounting points been selected?
- Have all screws been fastened tightly?
- Does the midsole mark of the plate align with the midsole mark of the ski?

MOUNTING

DRILL TEMPLATE RACEPLATE WCR SHORT / TEAM



1. COMPATIBILITY

Presently the drill template Raceplate WCR SHORT / TEAM can be used for:

PLATES:

RACEPLATE WCR 14 SHORT, RACEPLATE WCR TEAM

The Raceplate WCR SHORT comes with 8 mm penetration screws and can be used with skis, groups G1 & G2. Drill template Raceplate WCR SHORT can be used for ski widths from 59 to 108 mm. For other skis use the template adapter set (Art. No. 162569). With this adapter set ski widths from 45 to 132 mm can be mounted.

2. POSITIONING THE DRILL TEMPLATE

Open the clamping jaws (2) by rotating the clamping handles (1) and then place template on the ski. Align the boot mid-sole indicator (3) with the midsole mounting mark on the ski. Be sure the template is evenly seated against the ski's top surface. Release clamping handles (1) and attach the template firmly to the ski.

NOTE: Some ski manufactures do not use the center of boot sole location method. Always follow the ski manufacturer's instructions.

3. DRILLING THE HOLES

If not otherwise specified by the ski manufacturer, use a 4.1 Ø x 9.0 mm drill bit for skis, groups G1 & G2. Use the silver bushings for the standard mounting position (Pict. 70). Use the black bushings for the short track mounting position and the golden bushings for the long track mounting position. Use the red/silver bushings for the additional long position. Use the red bushings only if you want to mount the optional logo plate or the interchangeable dampener kit (Art.No. 163082).

If required by the ski manufacturer, tap the hole. After drilling place a drop of ELAN glue into the holes. It lubricates the screws and seals the holes.



4. MOUNTING

4.1. MOUNTING - RACEPLATE WCR SHORT

Place the mounting rail onto the prepared holes and fasten the screws in a cross pattern (Pict. 70).

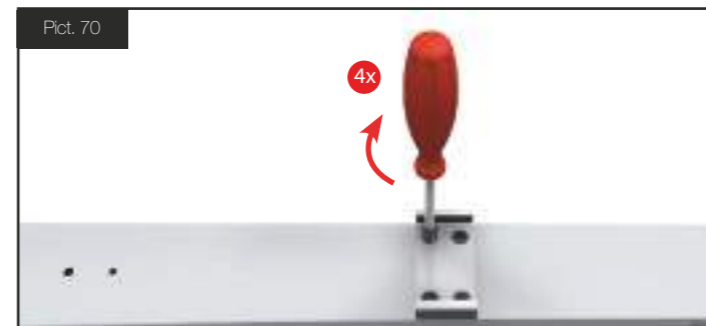

Slide in the plate until the midsole indicator aligns with the midsole mounting mark on the ski (Pict. 71).

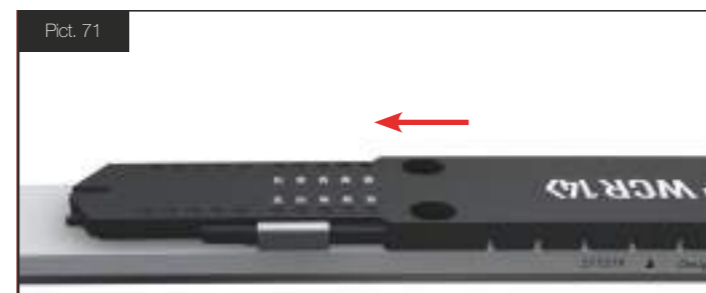

Check if the holes align with the prepared holes in the ski and fasten the screws as shown below (Pict. 72).

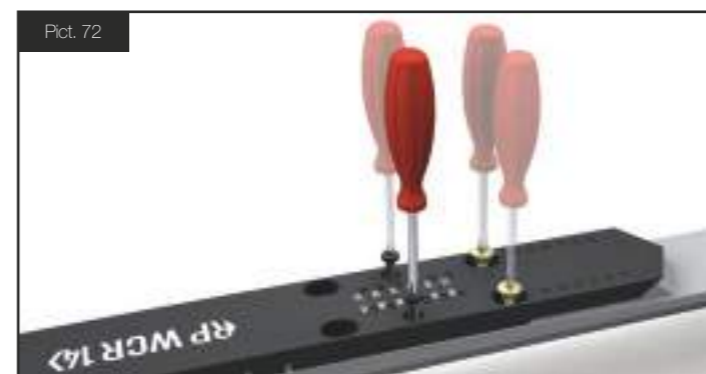

Slide on the cap and place the logo plate (optional) onto the prepared holes and fasten the screws. To fasten the fixing screw of the cap it is not recommended to use a screw shooter as it is possible to overturn the screw (Pict. 73).



4.2. MOUNTING - BINDING

Use only the pre-drilled holes for installation – do not drill holes into the plate to mount bindings of other manufacturers. Determine the boot sole length with the ELAN Rental boot caliper and place the binding on the plate corresponding with the appropriate printed length markings. Mount the binding in accordance with the procedures in this manual.



5. FINAL CHECK

- Have the proper mounting points been selected?
- Have all screws been fastened tightly?
- Does the midsole mark of the plate align with the midsole mark of the ski?

MOUNTING

DRILL TEMPLATE RACEPLATE 09

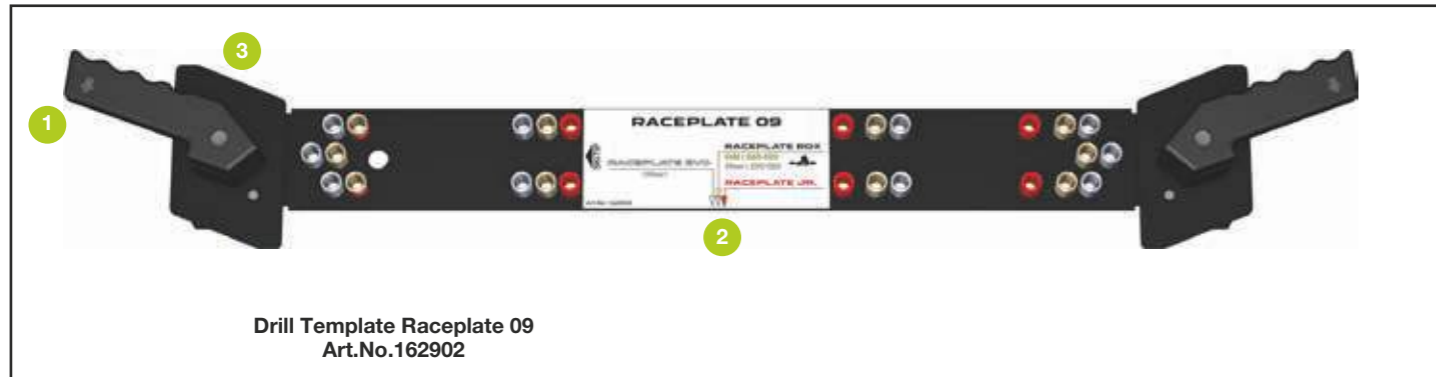

1. COMPATIBILITY

Presently the drill template RACEPLATE 09 can be used for:

PLATES:

RACEPLATE Junior EP 11.5 DUO, Raceplate EVO 14

Drill template RACEPLATE 09 is for mounting of RACEPLATE EVO and RACEPLATE Junior. It can be used for ski widths from 59 mm to 108 mm. For other skis use the template adapter set (Art. No. 162569). With this adapter set, you can mount skis from 45 mm to 132 mm. The following chart shows which bases and plates are suitable for the different ski-groups (G1-G4).

MODEL	G1	G2	G3	G4
RACE PLATE EVO 14	x	x	x	o

x ...suitable o ...not suitable

If bases and plates are mounted on other ski groups, the penetration depth and the torque moment of the screws have to be verified.

2. POSITIONING THE DRILL TEMPLATE

Open the clamping jaws (3) by rotating the clamping handles (1) and then place the template on the ski. Align the boot midsole indicator (2) for the appropriate model with the midsole mounting mark on the ski. Be sure the template is evenly seated against the ski's top surface. Release clamping handles.



NOTE: Keep in mind that some ski manufacturers do not use the center of boot sole location method. Always follow the ski manufacturer's instructions.

3. DRILLING THE HOLES

If not otherwise specified by the ski manufacturer use a 4.1 Ø x 9.0 mm drill bit for RACEPLATE EVO, as it comes with 8 mm penetration screws. For RACEPLATE Junior, with 6 mm penetration screws, use a 4.1 Ø x 7.0 mm drill bit, if not otherwise recommended.

DRILL THROUGH THE APPROPRIATE BUSHINGS

Version / Boot sole length	Color of bushings/ indicators
RACEPLATE EVO (261 - 372 mm)	silver

After drilling place a drop of the glue into the holes. It lubricates the screws and seals the holes.

4. MOUNTING - RACEPLATE EVO

4.1. MOUNTING - PLATE

First place the metal base plate over the front two holes and tighten the screws (Pict. 76). Then place the second metal base plate over the two holes in the back and tighten the screws (Pict. 77).



Slide in the front plate into the metal base plate in the front until the holes in the plate align with the holes in the ski. Do the same also for the back part of the plate (Pict. 78).



Now you can fix the plate. Just tighten the screws – the special golden screws in the oblong holes and the standard black screws in the normal holes (Pict 79).

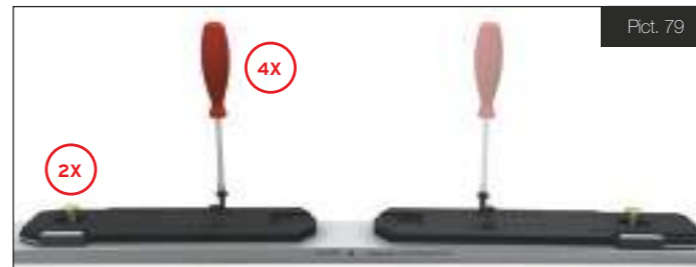

Finally place the mid part metal plate between the plates in the front and back so the holes align and tighten the screws (Pict 80).

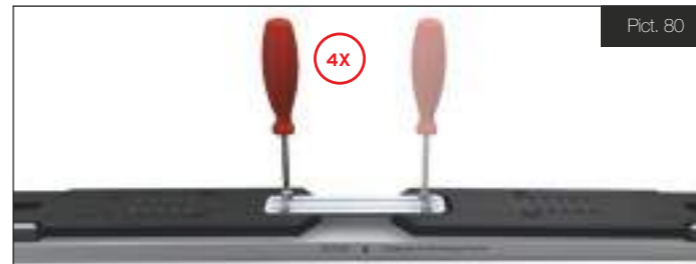

4.2. MOUNTING - BINDING ON PLATE

The Raceplate EVO is suited for all ELAN two-piece bindings, Freeflex bindings and rental bindings for boot sole lengths from 261 – 372mm. Simply mount the binding by placing the binding over the holes indicating the appropriate boot sole length and tighten the screws (Pict. 81).



NOTE: Use only the pre-drilled holes for installation – do not drill holes into the plate to mount bindings of other manufacturers. Other than those two points, the mounting is the same as the method described in this manual in chapter template 92W!

MOUNTING

DRILL TEMPLATE FREEFLEX DEMO

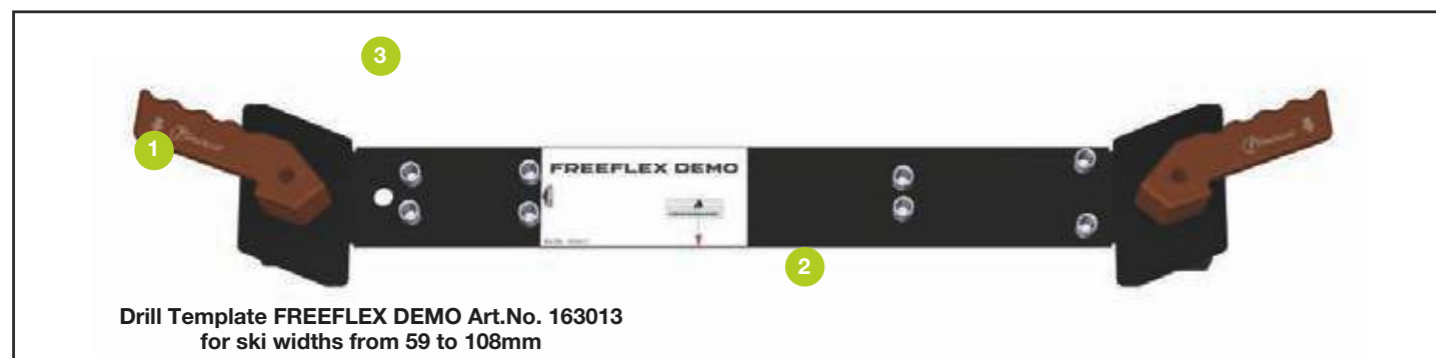

1. COMPATIBILITY

Presently the drill template FREEFLEX DEMO can be used for:

BINDINGS:

FREEFLEX DEMO 14 GW

All ELAN adult bindings come with 8 mm penetration screws and can be used with skis, of groups G1 & G2. The FREEFLEX DEMO 14 GW bindings are fully GripWalk compatible and can be used with Adult Alpine ski boots (ISO 5355 TYPE A) and GripWalk ski boots (ISO 23223 TYPE A)*. No further adjustment to the boot sole type is necessary. Every GripWalk compatible binding is indicated with the GripWalk logo on the AFS and also in the Product name with "GW". Drill template FREEFLEX DEMO can be used for ski widths from 59 mm to 108 mm. For other skis use the template adapter set (Art. No. 162569). With this adapter set, you can mount skis from 45 mm to 132 mm.

NOTE: ELAN offers different types of brakes. Refer to the brake overview on page 90 for brake and binding compatibility. The description of the brakes always includes a number and a color-letter code. This number stands for the maximum ski width in the brake area and not in the ski center! The color letter code defines the brake segment.

2. MOUNTING ON FLAT SKIS

POSITIONING THE DRILL TEMPLATE

Open the clamping jaws (3) by rotating the clamping handles (1) and then place the template on the ski. Align the boot midsole indicator (2) for the appropriate binding model with the midsole mounting mark on the ski. Be sure the template is evenly seated against the ski's top surface. Release the clamping handles (1) and attach the template firmly to the ski.

NOTE: Some ski manufactures do not use the center of boot sole location method. Always follow the ski manufacturer's instructions.

DRILLING THE HOLES

If not otherwise specified by the ski manufacturer, for all FREEFLEX DEMO models use a 4.1 Ø x 9.0 mm drill bit for skis, groups G1 & G2. If required by the ski manufacturer, tap the hole. After drilling place a drop of TYROLIA glue into the holes. It lubricates the screws and seals the holes.



MOUNTING

Place the metal toe track over the front holes and fasten the two front screws (Pict. 83).



Place the heel unit with its brake, guide and track over the holes, connect the Freeflex band with the the metal toe track and tighten the screws in a cross pattern (Pict. 84).



3. MOUNTING ON PLATES

MOUNTING

If you want to mount the Freeflex Demo bindings onto a HEAD/ TYROLIA plate, you don't need a drill template and drill holes.

NOTE: For mounting the Freeflex Demo bindings onto the Raceplate WCR short remove the front dampener of the metal toe track. Simply place the metal toe track over the holes indicated with the SP / DEMO marking. Tighten the front two screws. Place the heel unit over the holes with the SP / DEMO markings, connect the Freeflex band with the metal toe track and tighten the remaining screws in a cross pattern (Pict. 85).



NOTE: Always remove the boot from the binding before adjusting.

6. FUNCTION CHECK

Before the newly mounted ski equipment is rented perform a complete functional check.

NOTE: In some countries rental equipment has to pass a Pre-Season Test (See the Rental section of this manual). The boot should not catch on the sole hold-down of the heel as it opens and closes.

BRAKE

Press the step-on plate (1) down by hand. The brake arms (2) must close and open automatically to the braking position when the step-on plate is released.

LATERAL ELASTICITY OF THE TOE

Press the boot laterally outward. The binding must re-center the boot easily and quickly from a 15mm lateral displacement.

7. FINAL CHECK

- Has the proper mounting point been selected?
- Have all screws been fastened tightly?
- Has the forward pressure setting been controlled?
- Has at least one full adjustment been made using a representative reference boot including Release- /Retention setting and momentum test?
- Has the functional check been passed successfully?
- Functional brake test passed?

4. ADJUSTMENT

Make sure that the boot meets the international standards and is free of any functional damage. Determine the boot sole length with the ELAN rental caliper (Art. No. 162617). Open the one touch latch and slide the toe piece on from the front. Adjust the toe piece to the desired position and close the latch. Push the one touch lever of the heel forward and slide the heel into the correct position. Let go of the lever and make sure that the heel snaps into position (Pict. 86).



5. FORWARD PRESSURE CONTROL

Place a suitable reference boot in the binding using the mm-scale for length adjustment and close it (Pict 87). Then check the indicator located at the rear end of the heel piece. With boot inserted the pointer should rest in the middle of the marked area. If necessary, re-adjust the boot sole length.



*except the boot models K2 BFC (2018 and older)

MOUNTING

DRILL TEMPLATE SP 2003 W

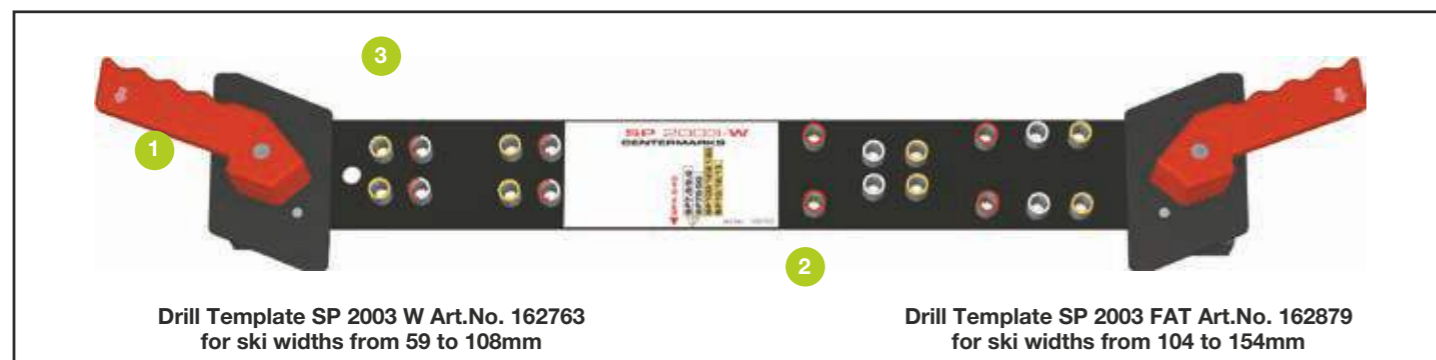

1. COMPATIBILITY

Presently the drill template SP 2003 W can be used for:

BINDINGS:

ESP 10.0 GW

All ELAN adult bindings come with 8 mm penetration screws and can be used with skis, of groups G1 & G2, except the ESP 10 GW (screws 6mm-G3/G4) (Art. No. 114395) model which is delivered with 6 mm penetration screws for G3 & G4 skis. The ESP 10 GW Bindings are now fully GripWalk compatible and can be used with adult Alpine ski boots (ISO 5355 TYPE A) and GripWalk ski boots (ISO 23223 TYPE A). No further adjustment to the boot sole type is necessary. Every GripWalk compatible binding is indicated with the GripWalk Logo on the AFS and also in the Product name with "GW". Drill Template SP 2003 W can be used for ski widths from 59 mm to 108 mm. For other skis use the template adapter set (Art. No. 162569). With this adapter set, you can mount skis from 45 mm to 132 mm with the standard SP 2003 W drill template.

NOTE: ELAN offers different types of brakes. Refer to the brake overview on page 90 for brake and binding compatibility. The description of the brakes always includes a number and a color-letter code. This number stands for the maximum ski width in the brake area and not in the ski center! The color letter code defines the brake segment.

2. POSITIONING THE DRILL TEMPLATE

Open the clamping jaws (3) by rotating the clamping handles (1) and then place the template on the ski. Align the boot midsole indicator (2) for the appropriate binding model with the midsole mounting mark on the ski. Be sure the template is evenly seated against the ski's top surface. Release the clamping handles (1) and attach the template firmly to the ski.

NOTE: Some ski manufactures do not use the center of boot sole location method. Always follow the ski manufacturer's instructions.

3. DRILLING THE HOLES

If not otherwise specified by the ski manufacturer, for all SYMPRO adult models use a 4.1 Ø x 9.0 mm drill bit for skis, groups G1 & G2. For ESP 7.5 AC and ESP 4.5 AC use a 4.1 Ø x 7.0 mm - drill bit for skis, groups G3 & G4.

Model	color of bushings/indicators
ESP 10 GW	yellow



If required by the ski manufacturer, tap the hole. After drilling place a drop of glue into the holes. It lubricates the screws and seals the holes.

4. MOUNTING

MOUNTING THE TOE

Connect the plastic mid section (3) with the metal toe track (1). Place the assembled toe track (1) over the holes and tighten the screws. Open the one touch latch (2) and slide the toe piece on from the front. Adjust the toe piece to the desired SINGLE CODE position and close the latch (2). (Pict. 90)



Make sure that the lever snaps in place completely ((it may be necessary to slide the toe forward and backwards slightly and to close the lever actively by hand).

MOUNTING THE HEEL

Place the heel unit with its brake, guide and track over the holes. Tighten the screws in a cross-pattern.

5. ADJUSTMENT

FOR ALL MODELS

Find adjustment ranges and some handling hints in the "SYMPRO SYMPRO" section of the Technical Manual. Take at least one reference boot satisfying all standards and free of functional damages to perform test adjustments with the binding.

USING THE SINGLE CODE

Adjust the heel to the corresponding alpha-settings (SINGLE CODE) of the ski boot.



IF A BOOT OF UNKNOWN SIZE IS USED PROCEED AS FOLLOWS:

Place the boot in the toe cup. Slide the heel piece forward until it just touches the boot. Close the binding and check the forward pressure.

ADJUSTING THE RELEASE VALUES

The release values of the toe and heel should be determined by height and body weight (ISO/ASTM) method. Set the binding accordingly with the adjustment screws at heel and toe unit. ELAN recommends adjusting these settings with a manual screwdriver. Do NOT use a screw shooter. We also recommend the use of a calibrated testing device and that you keep a written record of whether the system passes or fails (requirement in the US).

NOTE: Release/ Retention settings above a release moment of 105 NM at the toe and 452 NM at the heel are higher than the international standards recommend and are used solely at the skier's own risk!

6. FORWARD PRESSURE CONTROL

Place a suitable reference boot in the binding and close it. Then check the indicator (see Pict. 92) located at the rear end of the heel piece. With boot inserted the pointer should rest in the marked area. If necessary, re-adjust the boot sole.

length.

NOTE: Always remove the boot from the binding before adjusting.



NOTE: There is no need to check forward pressure in the adjustment process if SINGLE CODE is used (Head boots with single code marking // all type of boots measured and marked with spare single code stickers).

7. FUNCTION CHECK

Before the newly mounted ski equipment is rented perform a complete functional check.

NOTE: In some countries rental equipment has to pass a Pre-Season Test (See the Rental section of this manual). The boot should not catch on the sole hold-down of the heel as it opens and closes.

BRAKE

Press the step-on plate (1) down by hand. The brake arms (2) must close and open automatically to the braking position when the step-on plate is released (Pict. 93).



LATERAL ELASTICITY OF THE TOE

Press the boot laterally outward. The binding must re-center the boot easily and quickly from a 15mm lateral displacement.

8. FINAL CHECK

- Has the proper mounting point been selected?
- Have all screws been fastened tightly?
- Has the forward pressure setting been controlled?
- Has at least one full adjustment been made using a representative reference boot including Release- / Retention setting and momentum test?
- Has the functional check been passed successfully?
- Functional brake test passed?

MOUNTING

DRILL TEMPLATE SR 2003 W

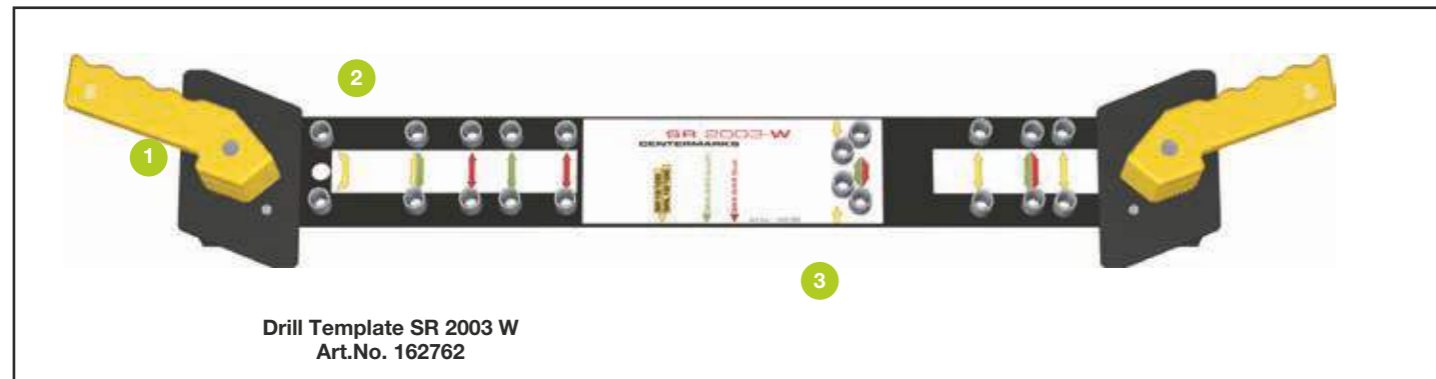

1. COMPATIBILITY

Presently the drill template SR 2003 W can be used for:

BINDINGS:

ESR 10.0 GW

ESR 10.0 GW comes with 8 mm penetration screws and can be used with skis, groups G1 & G2.

Drill template SR 2003 W can be used for ski widths from 59 to 108 mm. For other skis use the template adapter set (Art. No. 162569). With this adapter set ski widths from 45 to 132 mm can be mounted.

NOTE: ELAN offers different types of brakes. Refer to the brake overview on page 90 for brake and binding compatibility. The description of the brakes always includes a number and a color-letter code. This number stands for the maximum ski width in the brake area and not in the ski center! The color letter code defines the brake segment.

2. POSITIONING THE DRILL TEMPLATE

Open the clamping jaws (2) by rotating the clamping handles (1) and then place template on the ski. Align the boot mid-sole indicator (3) for the appropriate binding model with the midsole mounting mark on the ski. Be sure the template is evenly seated against the ski's top surface. Release clamping handles (1) and attach the template firmly to the ski.

NOTE: Some ski manufactures do not use the center of boot sole location method. Always follow the ski manufacturer's instructions.

3. DRILLING THE HOLES

If not otherwise specified by the ski manufacturer, for all SYMPRENT adult models use a 4.1 Ø x 9.0 mm drill bit for skis, groups G1 & G2.

DRILL THROUGH THE APPROPRIATE BUSHINGS

Model	color of bushings/indicators
ESR 10.0 GW	yellow



If required by the ski manufacturer, tap the hole. After drilling place a drop of glue into the holes. It lubricates the screws and seals the holes.

4. MOUNTING

MOUNTING THE TOE

Place toe piece on the prepared holes and drive the screws.

MOUNTING THE HEEL

Place the heel unit with its brake, guide and track over the holes. Tighten the screws in a cross pattern.



5. ADJUSTING THE RELEASE VALUES

FOR ALL MODELS

Find adjustment ranges and some handling hints in the SYMPRO/ SYMPRENT section of the Technical Manual. Take at least one reference boot satisfying all standards and free of functional damages to perform test adjustments with the binding.

USING THE SINGLE CODE

Adjust the heel to the corresponding alpha-setting (SINGLE CODE) of the ski boot (Pict. 96).



IF A BOOT OF UNKNOWN SIZE IS USED PROCEED AS FOLLOWS:

Place the boot in the toe cup. Slide the heel piece forward until it just touches the boot. Close the binding and check the forward pressure.

ADJUSTING THE RELEASE VALUES

The release values of the toe and heel should be determined by height and body weight (ISO/ASTM) method. Set the binding accordingly with the adjustment screws at heel and toe unit. ELAN recommends adjusting these settings with a manual screwdriver. Do NOT use a screw shooter. We also recommend the use of a calibrated testing device and that you keep a written record of whether the system passes or fails (requirement in the US).

NOTE: Release/ Retention settings above a release moment of 105 NM at the toe and 452 NM at the heel are higher than the international standards recommend and are used solely at the skier's own risk!

6. FORWARD PRESSURE CONTROL

Place a suitable reference boot in the binding and close it. Then check the indicator (see Pict. 97) located at the rear end of the heel piece. With boot inserted the pointer should rest in the marked area.



NOTE: If the forward pressure is not correct, readjust the boot sole length and check the SINGLE CODE. Please make sure that no boot is placed in the binding during adjusting!

7. FUNCTION CHECK

Before newly mounted ski equipment is rented perform a complete functional check.

NOTE: In some countries rental equipment has to pass a Pre-Season Test (See the Rental section this manual). The boot should not catch on the sole hold-down of the heel as it opens and closes.

BRAKE

Press the step- on plate (1) down by hand. The brake arms (2) must close and open automatically to the braking position when the step-on plate is released (Pict. 98).



LATERAL ELASTICITY OF THE TOE

Press the boot laterally outward. The binding must recenter the boot easily and quickly from a 15 mm lateral displacement.

8. FINAL CHECK

- Has the proper mounting point been selected?
- Have all screws been fastened tightly?
- Has the forward pressure setting been controlled?
- Has at least one full adjustment been made using a representative reference boot including Release- / Retention setting and momentum test?
- Has the functional check been passed successfully?
- Functional brake test passed?

MOUNTING

DRILL TEMPLATE TOUR PT



1. COMPATIBILITY

Presently the drill template TOUR PT can be used for:

BINDINGS:

ALMONTE 12 PT, ALMONTE 10 PT, ALMONTE 10 PT DEMO

All ALMONTE PT bindings come with 8 mm penetration screws and can be used with skis of groups G1 and G2. If recommended by the ski manufacturer use shorter screws with a penetration depth of 6 mm. Drill template TOUR PT can be used for ski widths from 75 to 125 mm. For other skis use the template adapter set (Art. No. 162569).

NOTE: ELAN offers different types of brakes. Refer to the Brake overview on page 90 for brake and binding compatibility. The description of the brakes always includes a number and a color-letter code. This number stands for the maximum ski width in the brake area and not in the ski center! The color letter code defines the brake segment.

2. ADJUSTING THE DRILL TEMPLATE

To adjust the template unlock the locking lever (1) by rotating it counter-clockwise to the far left position.

Place the ski boot in the template and push the handles together until the stops (2) come in contact with the ski boot sole. Lock the lever to the far right position to prevent length change, and then take the boot out of the template.

Please use the following length markings for the DEMO version:

VERSION	LENGTH POSITION
ALMONTE PT DEMO	25 cm

Place the template on the ski and center the jig. Therefore open the clamping jaws (4) by rotating the clamping handles (2) and then place the template on the ski. Select the right midsole indicator (3) on the template (White for RETAIL ALMONTE or Red for the DEMO version), align the indicator with the midsole mounting mark on the ski.



Release the handles and ensure that the template is evenly seated against the ski's top surface. Select the right holes! You just have to select the right bushings for the holes:

VERSION	LENGTH POSITION
ALMONTE PT	silver
ALMONTE PT DEMO	red

3. DRILLING THE HOLES

If not otherwise specified by the ski manufacturer, use a 4.1 Ø x 9 mm drill bit for the toe and the heel track (8 holes) if required by the ski manufacturer, tap the holes. After drilling, place a drop of TYROLIA glue into the holes. It lubricates the screws and seals the holes.

4. MOUNTING

4.1. MOUNTING THE BRAKE

Therefore open the brake by pulling the brake arms apart then hook the brake into the heel housing (Pict.100).



4.2. HEEL UNIT

Just start with mounting the base unit of the binding depending on the version. Place the base unit over the rear holes and fasten all four screws in a cross pattern (Pict.101)



Slide the heel unit from the back onto the track by using a screwdriver. Stay on the track between the MAX and STOP marking (Pict.102).



4.3. TOE UNIT

4.3.1. RETAIL TOE UNIT

Place the toe unit over the holes and fasten all four screws in a cross pattern (Pict.103)

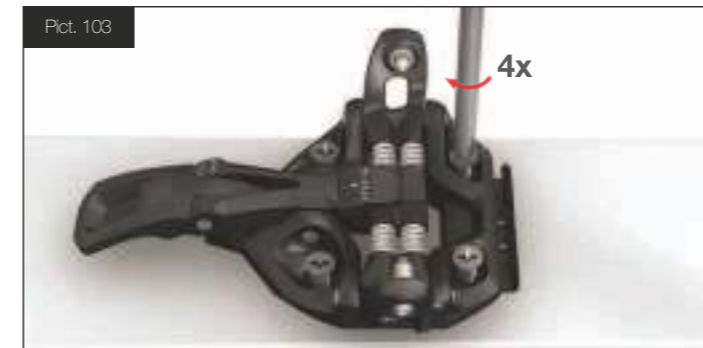

4.3.2. DEMO-TOE UNIT

Start with mounting the Toe demotrack by placing the track over the holes (Pict.104).



4.4. ADJUSTMENT OF THE HEEL PIECE

Place the ski boot in the binding. Therefore place the tip of the Ski boot right above the pins. Make sure pins and pin inserts align. Push the boot down until the pins engage with the inserts (Pict.105).

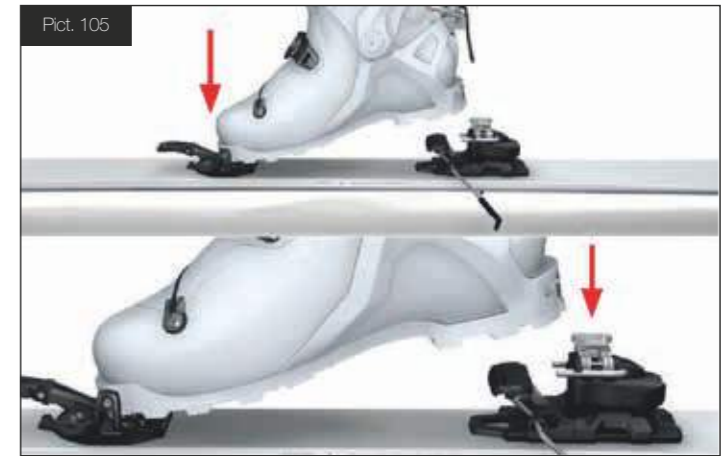

Then push down the heel, until the heel engages the U-Pin (Pict.138). Insert the LIGHT GAP TESTER. Screw the heel unit until the gap tester is hardly moveable (Pict.106 and Pict.107).



4.5. ADJUSTMENT OF THE RELEASE VALUE

The release values of the heel should be determined by height and body weight (ISO/ASTM) method. Set the binding according to the calculated DIN value by aligning the marked edge of the adjustment screw with the Release/Retention value on the scale (Pict.108). ELAN recommends adjusting these settings with a manual screwdriver. Do NOT use a screw shooter.



4.6. EXCHANGE THE U-PIN

4.6.1. PICKING THE RIGHT U-PIN

ELAN offer three different options for the U- Pin:

ART. NO.		RECOMMENDED RELEASE VALUE
163171	SOFT	4-8
163172	MEDIUM	6-10
163173	HARD	8-12



The MEDIUM U-Pin is premounted on all ALMONTE bindings.

ATTENTION: The recommended release values are overlapping so that for example the soft and the medium could both fit for the release value 7. Picking the right u-pin then is depending on personal preference.

4.6.2. REMOVING THE U-PIN

Remove the screw by using a TX 10 screwdriver (Pict.110).



Remove the cover by lifting it up and pushing it to the side (Pict. 111 and Pict. 112).

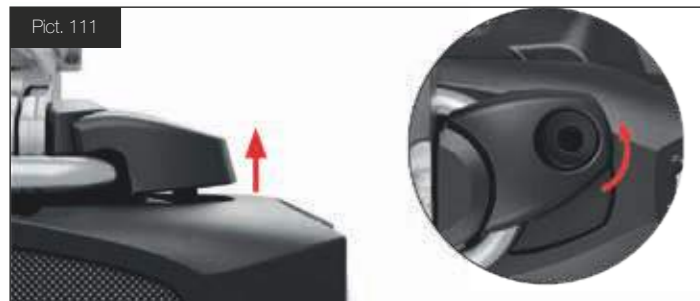

Next, remove the U-pin. Therefore take a hammer and a piece of wood or soft plastic and start carefully tapping out the U-pin as shown in the picture (Pict.113).

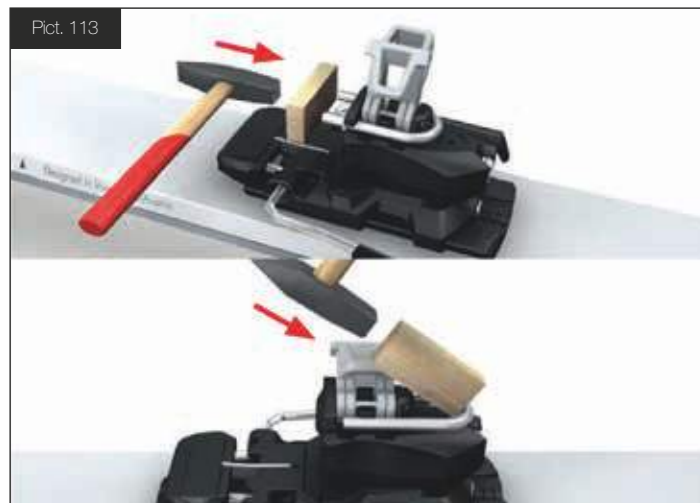

4.6.3. MOUNTAIN THE U-PIN

Take the right U-pin and start pushing it back in place. Use a hammer and again the piece of wood (to prevent damaging the U-pin) if necessary (Pict.114).



Screw the cover back onto the binding (Pict.115).



4.7. PERFORMANCE SPACER

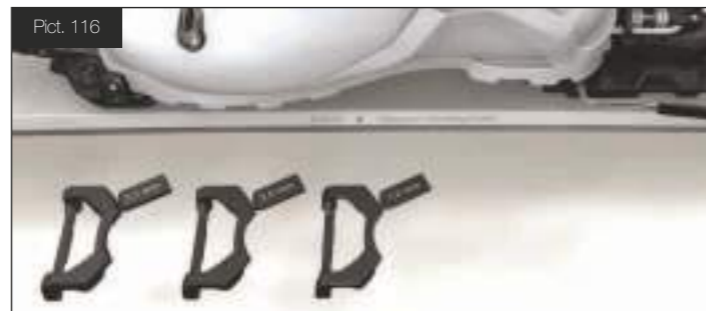

Elan offers three different sizes for the performance spacer. 1.5, 2.5 and 3.5 in order to accommodate nearly all different Boots.

4.7.1. CHOOSING THE RIGHT SPACER

First place your skiboot on your binding. Then start with the thickest spacer and try to put it in between the bootsole and the brake pedal (Pict.117). The thickest Spacer that fits between the bootsole and the brake pedal is the right one.



After finding the right spacer remove the part with the mm marking on it (Pict. 118).



4.7.2. MOUNTAIN THE SPACER

Start by placing the spacer onto the brake pedal (Pict.119) Then push the spacer simultaneously on both edges over the pedal.



Now push down the performance spacer (Pict. 120) until it snaps in.

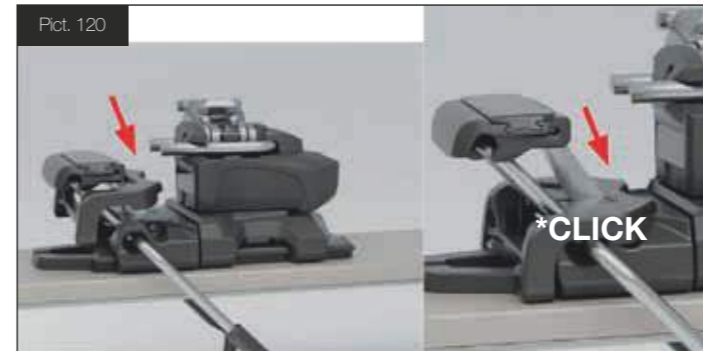

4.7.3. REMOVING THE PERFORMANCE SPACER

For removing the spacer, start to lift up the front of the spacer, we recommend using a small flat screwdriver to do that task (Pict. 121).



The spacer should now no longer be attached. Begin tilting the spacer onto the brake pedal. Further than push the spacer completely on and then over the pedal (Pict.122 and Pict. 123).



4.8. INSTALL THE TOURNIG LEASH

Start by installing the included loop on the touring leash as shown in pict. 124.



Next put the loop through the wing. Now take the other end of the leash and push it completely through the loop (Pict. 125).



Your knot should now look like in the picture 126.



Place the other side of the leash somewhere you prefer on the boot. (Pict.127)



5. FINAL CHECK

- Has the correct mounting point been selected?
- Have all screws been fastened tightly?
- Functional Brake test passed?

MOUNTING FUSION X

1. COMPATIBILITY

FUSION X is ELAN's next generation of high performance binding system. :

SCALE SIZE	L	XL
RANGE (MM)		
PLATE NAME	Quick Shift 255-355 mm	
	Light Shift 255-355 mm	Light Shift 271-371 mm
	Power Shift 255-355 mm	Power Shift 271-371 mm
SKI TYPE	Women Unisex	Women Unisex
Unisex/Women Ski lengths	SKI ≤ 154	155 ≤ SKI
Model Freeline	95 125 135	
Reccomended bindings	din 9.0 - 11.0	din 9.0 - 11.0

All ELAN's FUSION X plates are pre-mounted on skis! Presently the FUSION X plates can be used for next bindings:

BINDINGS:
PROTECTOR 13 GW FUSION X, PROTECTOR 11 GW FUSION X, EMX 14.0 GW FUSION X, EMX 12.0 GW FUSION X, EMX 11.0 GW FUSION X, EMX 11.0 GW FUSION X, EM 11.0 GW FUSION X

2. MOUNTING - BINDINGS

Mounting and adjusting the FUSION X bindings is extremely simple and can be done without any additional tool.

Make sure that the boot meets the international standards and is free of any functional damage. Take the binding parts out of the box and follow the steps on the instruction leaflet. Determine the boot sole length with the rental boot indicator (Pict.128), (Art. no. 162617).

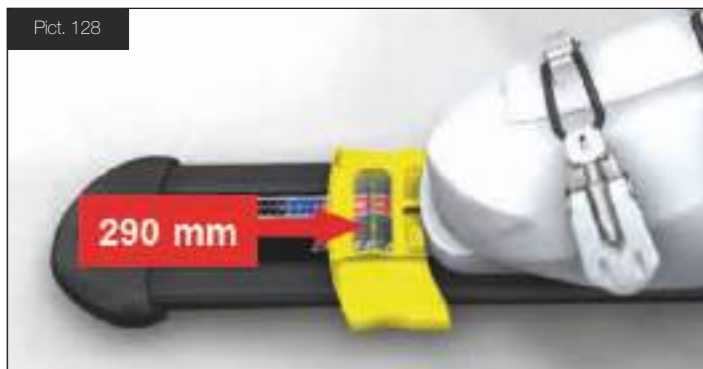

First you have to open the toe-lever and slide the toe on the rail from the front. Lock at the appropriate boot sole length and close the lever.



Now hook the brake into the heel housing (Pict.129).



Then you can open the lever and slide the heel on the rail from the back! Simply lock it at the appropriate boot sole marking by closing the lever. (Pict.131).



If you have too much or not enough forward pressure, check the settings at first. If necessary, adjust slightly at the heel and the toe (Pict.132).

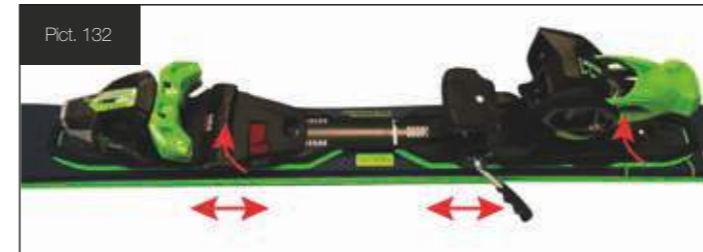

The release values at toe and heel should be determined by the height and body weight (ISO/ ASTM) method. Set the binding accordingly with the adjustment screws. We recommend the use of a calibrated testing device and that you keep a written record of whether the system passes or fails (requirement in the US).

NOTE: Release/ Retention settings above a release moment of 100Nm at the toe and 425Nm at the heel are higher than the international standards recommend and are used solely at the skier's own risk!

3.1. ADJUSTMENT OF LATERAL HEEL RELEASE

For PROTECTOR Bindings, in addition to the toes and heels, set the release/retention setting of the lateral heel release according to the initial indicator setting. The adjustment screw for the lateral heel release is indicated on the product by a red "ADJUSTMENT" print around the screw head.



NOTE: The setting for the lateral heel release can differ from the final indicator setting on toes and heel as it always stays on the initial indicator setting! No further testing or adjustment is necessary. ELAN guarantees optimal function to keep you safe!

4. FUNCTION CHECK

Check the function of the heel. Make sure that the boot does not catch on the heel during entry and exit. Check the brake function by pressing down the brake pedal (1) by hand. The brake arms (2) must open to the braking position when the brake pedal is released (see Pict.134).



Check the elasticity and retention of the toe by pushing the boot inward and outward. The binding must re-center the boot easily and quickly from a 15mm lateral displacement.

5. FINAL CHECK

- Is the proper mounting point selected?
- Functional brake test passed?
- Have all locks been closed correctly?
- Is the forward pressure properly adjusted?
- Are the release values of the toe and the heel properly determined and set?
- Is the Instruction for use booklet ready to be handed over to the customer?
- Are the release values of the lateral heel release properly determined and set? (PROTECTOR)

For Voyager see the video on the link below or scan the code:
elanskis.com/voyager-101



MOUNTING SHIFT

1. COMPATIBILITY

ELAN offers three types of SHIFT plates, the QuickShift (QS), LightShift (LS) and PowerShift (PS) plate:

RANGE (MM)	
PLATE NAME	Fusion X 255-378 mm
SKI TYPE	Unisex
Junior Ski Lengths	
Junior twintip Ski Lengths	
Unisex/Women Ski lengths	154 ≤ SKI
Model Freeline	
Reccomended bindings	din 11.0 - 14.0

All ELAN's SHIFT plates are pre-mounted on skis! Presently the SHIFT plates can be used for next bindings:

BINDINGS:

ELX 11.0 GW SHIFT Brake 85, ELS 11.0 GW SHIFT Brake 85, ELS 11.0 GW SHIFT Brake 90, EL 10.0 GW SHIFT Brake 85, EL 10.0 GW SHIFT Brake 90, EL 9.0 GW SHIFT Brake 85, ELW 11.0 GW SHIFT Brake 85, ELW 10.0 GW SHIFT Brake 85, ELW 9.0 GW SHIFT Brake 85, EL 7.5 GW CA SHIFT Brake 78, EL 7.5 GW CA SHIFT Brake 90, EL 4.5 GW CA SHIFT Brake 80

2. MOUNTING - BINDINGS

Mounting and adjusting the SHIFT bindings is extremely simple and can be done without any additional tool.

Make sure that the boot meets the international standards and is free of any functional damage. Take the binding parts out of the box and follow the steps on the instruction leaflet. Determine the boot sole length with the rental boot indicator (Pict.136), (Art. no. 162 617).



First you have to open the toe-lever and slide the toe on the rail from the front. Lock at the appropriate boot sole length and close the lever.



Now hook the brake into the heel housing (Pict.138).



Then you can open the lever and slide the heel on the rail from the back! Simply lock it at the appropriate boot sole marking by closing the lever - and you are ready to go! (Pict.139).



3. ADJUSTMENT OF THE RELEASE VALUES

The release values at toe and heel should be determined by the height and body weight (ISO/ ASTM) method. Set the binding accordingly with the adjustment screws. We recommend the use of a calibrated testing device and that you keep a written record of whether the system passes or fails (requirement in the US).

NOTE: Release/ Retention settings above a release moment of 100Nm at the toe and 425Nm at the heel are higher than the international standards recommend and are used solely at the skier's own risk!

4. FUNCTION CHECK

Finally, check the forward pressure, by placing a boot into the binding. If you have followed all steps correctly, the indicator should rest in the marked area (Pict.140).



If you have too much or not enough forward pressure, check the settings at first. If necessary, adjust slightly at the heel and the toe (Pict.141).



Then check the forward pressure again.

Check the function of the heel. Make sure that the boot does not catch on the heel during entry and exit. Check the brake function by pressing down the brake pedal (1) by hand. The brake arms (2) must open to the braking position when the brake pedal is released (see Pict.142).

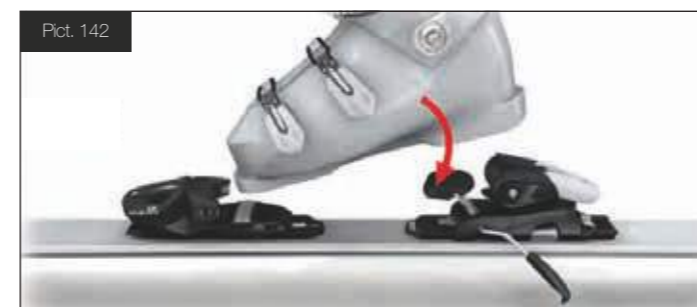

Check the elasticity and retention of the toe by pushing the boot inward and outward. The binding must re-center the boot easily and quickly from a 15mm lateral displacement (EL 7.5 AC Shift, EL 4.5 AC Shift - 10mm).

5. FINAL CHECK

- Is the proper mounting point selected?
- Functional brake test passed?
- Have all locks been closed correctly?
- Is the forward pressure properly adjusted?
- Are the release values of the toe and the heel properly determined and set?
- Is the instruction for use booklet ready to be handed over to the customer?

MOUNTING

JRS JUNIOR SHIFT

1. COMPATIBILITY

SCALE SIZE	"S"	"M"	"L"
RANGE (MM)	183-282	215-314	255-354
PLATE NAME	JRS	JRS	JRS
SKI TYPE	Kid	Junior	Junior
Junior Ski lengths	70	110	130
	80	120	140
	90		150
	100		
Junior twintip Ski lengths		95	125
		105	135
		115	145
Unisex/Women Ski lengths			
Model Freeline			
recommended bindings	din 4.5	din 4.5	din 7.5

JRS is ELAN's next generation of high performance binding system.

All ELAN's JRS plates are pre-mounted on skis! Presently the JRS plates can be used for next bindings:

BINDINGS:
EL 7.5 GW CA JRS Brake 78, EL 7.5 GW CA JRS Brake 90, EL 4.5 GW CA JRS Brake 80

2. MOUNTING - BINDINGS

Mounting and adjusting the FUSION X bindings is extremely simple and can be done without any additional tool.

Make sure that the boot meets the international standards and is free of any functional damage. Take the binding parts out of the box and follow the steps on the instruction leaflet. Determine the boot sole length with the rental boot indicator (Pict.143), (Art. no. 162 617).

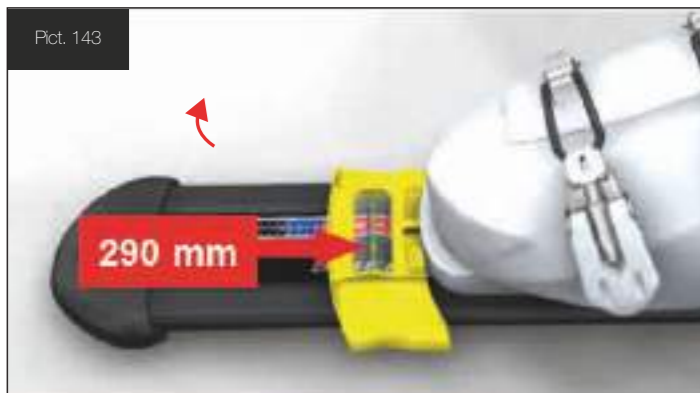

First you have to open the toe-lever and slide the toe on the rail from the front. Lock at the appropriate boot sole length and close the lever.

Now hook the brake into the heel housing (Pict.144).



Then you can open the lever and slide the heel on the rail from the back! Simply lock it at the appropriate boot sole marking by closing the lever. (Pict.146).



3. ADJUSTMENT OF THE RELEASE VALUES

Finally, check the forward pressure, by placing a boot into the binding. If you have followed all steps correctly, the indicator should rest in the marked area (Pict.148).



If you have too much or not enough forward pressure, check the settings at first. If necessary, adjust slightly at the heel and the toe (Pict.149)

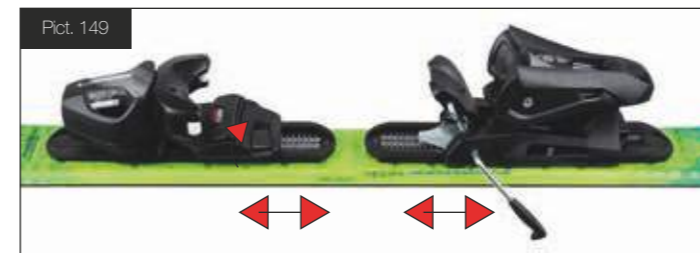

The release values at toe and heel should be determined by the height and body weight (ISO/ ASTM) method. Set the binding accordingly with the adjustment screws. We recommend the use of a calibrated testing device and that you keep a written record of whether the system passes or fails (requirement in the US).

NOTE: Release/ Retention settings above a release moment of 100Nm at the toe and 425Nm at the heel are higher than the international standards recommend and are used solely at the skier's own risk!

4. FUNCTION CHECK

Check the function of the heel. Make sure that the boot does not catch on the heel during entry and exit. Check the brake function by pressing down the brake pedal (1) by hand. The brake arms (2) must open to the braking position when the brake pedal is released (see Pict.150).



Check the elasticity and retention of the toe by pushing the boot inward and outward. The binding must re-center the boot easily and quickly from a 15mm lateral displacement.

5. FINAL CHECK

- Is the proper mounting point selected?
- Functional brake test passed?
- Have all locks been closed correctly?
- Is the forward pressure properly adjusted?
- Are the release values of the toe and the heel properly determined and set?
- Is the Instruction for use booklet ready to be handed over to the customer?
- Are the release values of the lateral heel release properly determined and set?

TECHNICAL INFORMATION

ELAN BRAKE LINE 2024/25

1. IDENTIFICATION AND NAMING SYSTEM

To make the brake-binding allocation as easy as possible, we are using a color coding system. In addition to the standard product labels of the spare brakes, a color-letter code is affixed on the brake boxes (single and master packaging).

All bindings will come with a fresh new packaging and a newly designed label containing a corresponding color-letter code. Matching brakes and bindings has become fast and easy. For a binding with a red sticker [A], the dealer just has to look for a brake with a red color-code [A] in the proper width. The segmentation and color-coding system can be found in the ELAN brake line on the next page.



Also the nomenclature of all ELAN brakes is standardized and includes all basic information. These nomenclatures consist of a clear name, a number, what defines the maximum ski width at the mounting point and a letter, what specifies the brake cluster.

85/95/110/130/150mm



2. DETERMINATION OF THE CORRECT BRAKE WIDTH

For brake selection, please refer to the ELAN brake line on page 90. There you can find a recommended ski width for every brake. Please make sure to select your brakes according to your ski width as brakes chosen too wide or too narrow may impair brake function!

If your brakes are too narrow, they will not clear the edges of your skis and will not deploy properly when your ski comes off. If the brakes are too wide, they may drag when you put your skis on edge, especially on steeper terrains or could interfere with other objects.

TECHNICAL INFORMATION

ELAN BRAKE LINE

2024/25

COLOR CODE	ELAN BINDING MODELS	ART. NO.	SALES CODE	BRAKE MODEL / WIDTH	ALL MOUNTAIN		FREERIDE TWIN			TOURING			FREERIDE					TWEENER	
					WINGMAN 86 C11 / T1 WILDCAT 86 CX	WINGMAN 82 C11 / T1 WILDCAT 82 CX / C	PLAYMAKER 111	PLAYMAKER 101	PLAYMAKER 91	RIPSTICK TOUR 104	RIPSTICK TOUR 94/94 W	RIPSTICK TOUR 88/88 W	RIPSTICK TOUR 80 T	RIPSTICK 116	RIPSTICK 108 & RIPSTICK 106 W	RIPSTICK 102 & RIPSTICK 100 W	RIPSTICK 96 & 94 W	RIPSTICK 88 / 88 W	LYNX 82 / UL / W
A	ER 18.0 X RD FREEFLEX ST ER 17.0 FREEFLEX ST ATTACK 17 MN ATTACK 14 MN ATTACK 11 GW ATTACK LYT 12 GW ATTACK LYT 11 GW	163033	DF163033000	Power Brake [®] Race PRO 17-85 [A]															
		163035	DF163035000	Power Brake [®] Race PRO 95 [A]															
		163036	DF163036000	Power Brake [®] Race PRO 110 [A]															
		163037	DF163037000	Power Brake [®] Race PRO 130 [A]															
C	AMBITION 12 MN	163099	DF163099000	BRAKE AMBITION 95 (C)															
		163100	DF163100000	BRAKE AMBITION 105 (C)															
		163101	DF163101000	BRAKE AMBITION 125 (C)															
D	ER 14.0 FREEFLEX, ER 11.0 / FREEFLEX, ER 14.0 GW FREEFLEX DEMO, ESP 10.0 GW, ESR 10.0 GW, ATTACK LYT 9 GW	163045	DF163045000	Power Brake [®] LD 95 [D]															
F	ATTACK 14 MN DEMO ATTACK 11 MN DEMO	163050	DF163050000	Powerrail Brake [®] LD 85 [F]															
		163051	DF163051000	Powerrail Brake [®] LD 95 [F]															
		163052	DF163052000	Powerrail Brake [®] LD 110 [F]															
		163053	DF163053000	Powerrail Brake [®] LD 130 [F]															
J	EL 10.0 GW EL 7.5 GW CA	162776	DF162776000	SL Brake 90 [J]															
	ALMONTE 12 PT ALMONTE 10 PT ALMONTE 10 PT DEMO	163161	DF163161000	Brake Tour 90 [M]															
		163162	DF163162000	Brake Tour 105 [M]															
		163163	DF163163000	Brake Tour 120 [M]															

*brake width

** For competition bindings (X) only

MOUNTING

BOOT SOLE TYPES - ISO STANDARDS

1. BOOT STANDARDS

Actually there are three different boot sole standards on the market. The ISO 5355 (corresponding to binding standard ISO 9642) defines Alpine boots for adults and children, the ISO 23223 defines Alpine boots with improved walking soles (GripWalk and GripWalk Junior) and the ISO 9523 (corresponding to binding standard ISO 13992) defines a wide range of touring ski boots.

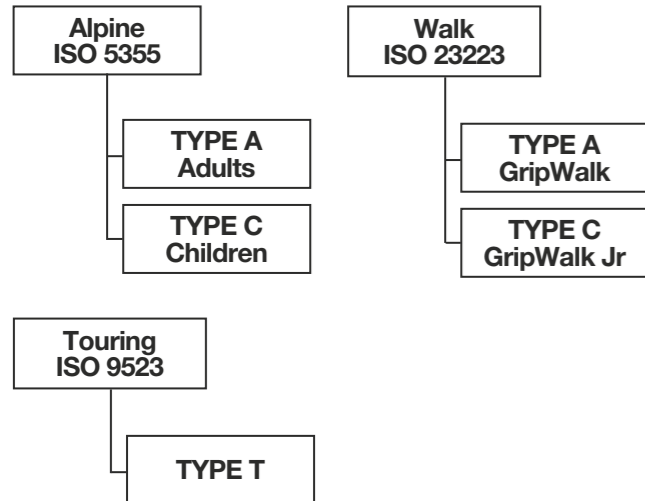

The new sub category (Walk) tries to combine the advantages of both previously existing standards:

- To offer more grip and better walkability compared to ALPINE boots. A profiled sole made of softer material offers a superior walking grip and is less slippery than a standard ski boot sole. A rockered sole offers a more comfortable natural roll motion.
- To also offer better skiability and increased safety compared to TOURING boots (hard contact area, stiffer material, alpine boot design) and the same safe release function and power transmission as an alpine boot.

2. BOOT IDENTIFICATION

In general, all boots should be marked with the corresponding standard. In most cases you will find the indication on the sole pads of the boot.

ALPINE BOOTS ISO 5355

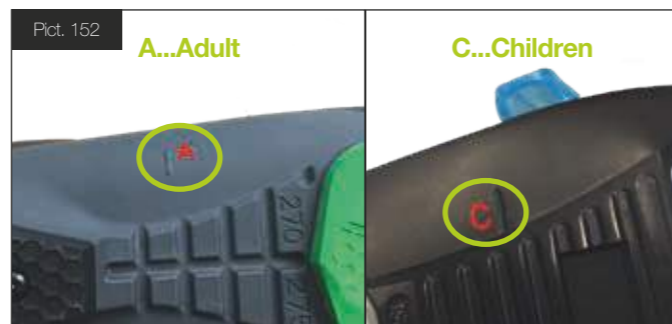

TOURING BOOTS ISO 9523

In case there is no other marking, in addition to ISO 9523, the boot is a regular Touring boot. The boot will only work in bindings with AT compatibility.



WALK BOOTS ISO 23223 TYPE A - GripWalk

To help identify a GripWalk boot the GripWalk icon and ISO marking (ISO 23223, but can be also ISO 9523 on older boots) are incorporated in the sole.



WALK BOOTS ISO 23223 TYPE C - GripWalk Junior

To help identify a GripWalk Junior boot, the GripWalk Junior logo and ISO marking (ISO 23223, can be missing on older boots) are incorporated in the sole pads.

NOTE: The boot is also marked with a sticker placed in the toe area. (pict 154 – right side). The sticker comes from the factory on boots with pre-mounted GripWalk soles or it needs to be placed in the toe area if the pads are retrofitted.

3. BOOT-BINDING COMPATIBILITY

In case of uncertainty, the dealer should check the instructions of use of the binding. It lists all compatible boot types:

E.g. for an Attack GW	E.g. for an Attack MN	E.g. for an GW CA model	E.g. for an ALMONTE PT
This binding model can be used with ski boots that meet the following current industry standards - ALPINE TYPE A (ISO 5355) and WALK TYPE A (ISO 23223)..	This binding model can be used with ski boots that meet the following current industry standards - ALPINE TYPE A (ISO 5355), WALK TYPE A (ISO 23223) and TOURING TYPE T (ISO 9523).	This binding model can be used with ski boots that meet the following current industry standards - ALPINE TYPE A and ALPINE TYPE C (ISO 5355), WALK TYPE A (GripWalk) (ISO 23223) WALK TYPE C (GripWalk Junior) (ISO 23223)	This binding model can be used with ski boots that meet the following current industry standards - WALK TYPE A with inserts and Touring (ISO 9523) with tech inserts.

BOOT - BINDING - COMPATIBILITY - CHART

The following chart shows the boot-binding compatibility of the current ELAN binding line:

 <i>Always Good Times</i>	ALPINE SKI BOOTS (ISO 5355)		WALK SKI BOOTS (ISO 23223)		TOURING SKI BOOTS (ISO 9523)
	TYPE A	TYPE C	TYPE A GRIP WALK	TYPE C GRIP WALK	
* marking can be found in the product name and partly also on the binding					
Binding without any indication*	●	/	/	/	/
Binding marked "GW CA"	●	●	●	●	/
Binding marked "GW"	●	/	●	/	/
Binding marked "MN"	●	/	●	/	●

MOUNTING

BOOT-HANDLING AND TESTING

VISUAL INSPECTION OF SKI BOOTS

In assembling a system for the skier, it is the responsibility of the shop to inspect and evaluate each equipment component. This inspection checklist should be followed before any mounting or adjusting is performed.

Ideally, they should be posted and used on the sales floor while the customer is still in the shop so that any deficiencies can be explained on the spot.

In retail, boots must pass all four points of this inspection before being accepted for use. In rental, this inspection is the first step in the "pre-season boot test procedure".

1. CHECK TYPE, SIZE AND OVERALL CONDITIONS

- Is the performance level appropriate for the skier?
- Is the size correct (SINGLE CODE, boot sole length)?
- Is all hardware intact and in working order?
- Is the boot free of excessive or asymmetric wear?
- Is the boot free of dirt or sole warp?

2. CHECK MATERIAL

- Binding contact surfaces require a high quality hard, low-friction material. Check both lower shell and any separately attached inserts.
- If you can easily scratch the surface of the sole with your fingernail, that's an indication of extremely soft material that can degrade system performance.

3. CHECK CONDITION OF BINDING CONTACT SURFACES, TOE AND HEEL

- Any scratches or other roughness should not be deeper than 1 mm.
- Check for any rocks, gum, or other foreign matter stuck to the sole.

4. VERIFY BOOT SOLE DIMENSIONS

- Ski boots must meet international standard specifications.
- Use the Boot Rental Indicator to determine whether wear is excessive. The most critical dimension for ELAN bindings is the front surface and height of the boot toe. Any boots worn past the indicated amounts should be repaired or not used with ELAN bindings.



THE BOOT INDICATOR Art. No. 162617

This rental boot device is a multifunction-tool:

1. Sole length: Put the boot in the device and slide the toe stop up to the boot toe. Read sole length in the window, used for ELAN rental bindings: the SINGLE CODE. Boot sole wear: The standardized interfaces (contact boot sole with sole lugs) are important in the functioning of ELAN bindings.
2. Boot toe bottom: Excessive wear is indicated if the lower edge of the front surface is at or above the bottom step on the appropriate child (C 2), adult (A 2) or touring (T 2) post (see Pict. 159).
3. Boot toe ledge height: With the toe stop against the boot toe, the level of the toe ledge should be at or above the top of the appropriate post, "Child" (C 1), "Adult" (A1) or "Touring" (T 1) (see Pict. 160). Replace toe pads if worn.

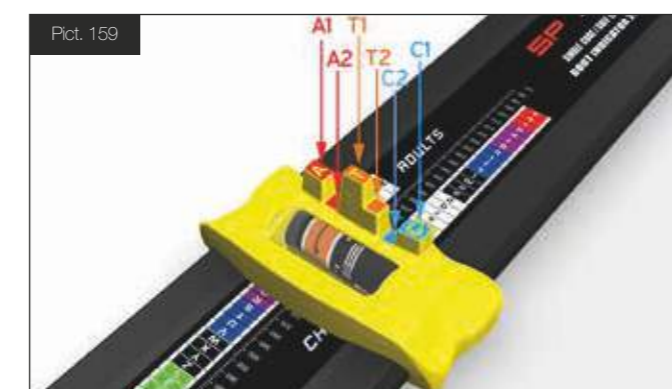

4. Heel height and wear: Check this boot standard with the same procedure used for the toe. The heel posts (A 3 + C 3) are located at the rear of the device (see Pict. 158).
5. The marks "A/C" help to select a "Child" boot from an "Adult" by indicating the standardized sole width.

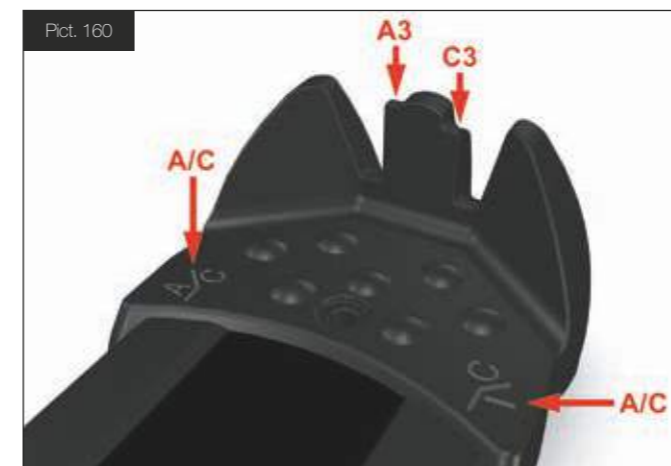

NOTE:

Any boot which passes points 3, 4 and 5, as well as conforming to the Visual Inspection Checklist, may be accepted for use with ELAN bindings.

Boots which fail any point should be repaired or replaced.

These checks apply only to boots used with ELAN bindings. Consult other binding manufacturers for their used boot specifications.

CLEAN VS. LUBRICATED SKI BOOT TEST

This test is designed to determine the influence of a given boot on the release characteristic of a binding. It should be performed on boots not meeting all the points of the boot visual inspection criteria, or if measured release values fall outside the system "inspection" tolerance. It is seen as the "last chance" for a boot to qualify before getting eliminated from inventory.

1. Clean the boot(s) to be tested with soap and water. Allow to dry.
2. Select an appropriate "reference" binding that has displayed release values within the Inspection Range on the Adjustment Chart. Clean the binding's boot contact surfaces with soap and water and allow to dry.
3. Test the binding and boot in Twist and Forward Lean at a mid-scale indicator value (Only one direction of twist is required).
4. In a further test run lubricate all boot/binding contact areas with soapy water. Retest in Twist and Forward Lean.
5. Results of each lubricated test should be within 20% of the corresponding results when tested clean.

Any boot which fails this test should not be used with An ELAN binding.

MAINTENANCE & SERVICE

1. VISUAL INSPECTION OF BINDINGS

In assembling a system for the skier, it is the responsibility of the shop to inspect and evaluate each equipment component. This inspection checklist should be followed before any mounting or adjusting is performed. Ideally, they should be posted and used on the sales floor

while the customer is still in the shop so that any deficiencies can be explained on the spot.

2. CHECK SUITABILITY

- Is the binding model appropriate for the skier's ability?
- The binding must be compatible with the customer's boot/ski.
- The skier's release/retention setting should fall within the binding's adjustment range. Additionally, we recommend that the skier's setting not be closer than one number from the minimum or maximum settings on the binding in order to allow for future readjustment.
- Are the mounting screw lengths appropriate for the ski being used?

3. CHECK THE CONDITION OF BINDING

- Are all parts present and in working order?
 - Is the AFD surface smooth and secure? If not, it should be replaced.
 - Are all mounting screws present or tight?
 - Does the binding show signs of contamination?
 - Has proper periodic lubrication been performed?
- Dried out or corroded bindings can function improperly.

4. RETAIL TESTING

Completion and documentation of the following Retail Test Procedures is recommended for U.S.: required under the terms of the ELAN Dealer Indemnity Program.

These tests should be conducted any time work is performed on a ski/ boot/binding system that may affect its release values. The procedure applies to all ELAN alpine bindings, new as well as used.

1. Follow ELAN procedures for inspection, mounting, adjustment, and maintenance as appropriate.
2. Confirm that toe and heel indicator values match those specified on the actual ELAN Adjustment Chart.
3. Using a calibrated testing device, according to its instructions for use, "exercise" the binding by releasing it at least once in each direction (clock-wise and counter clockwise at the toe, vertically at the heel). Then measure Twist and Forward Lean Torque Values. The middle quantitative value of 3 releases in each direction should be used as the test result.
4. Compare Twist and Forward Lean test results with the System Inspection Ranges on the actual ELAN Adjustment Chart.
5. If any test results fall outside the System Inspection Range, consult ELAN Troubleshooting Procedures which follow this section.
6. With testing complete, the ELAN Certified Mechanic must complete and sign the workshop ticket. Be sure the Final Indicator Settings are correctly shown there.

The workshop ticket should simply reflect that the system has "passed all tests" or that "all manufacturer's procedures have been completed".

5. REPLACING THE BRAKE

If the brake feels too hard or blocks during the hand test, if the brake arms are damaged, if the pedal is worn out or if a wider brake is necessary then the brake should be replaced immediately.

ELAN offers different brakes for almost every binding. Refer to the brake overview on page 88 for brake and binding compatibility. To change the brake, all you have to do is to unscrew the old brake and replace it with

the proper brake previously selected for the binding. In order to fix the brake, tighten the screws. On rail-bindings, the brake is hooked into the heel housing and not fixed with screws. Slide the heel off from the rails and replace the brake (Pict. 160).



6. REPLACING THE GLIDE INSERTS

POWERRAIL BINDINGS

To provide unaffected long-term performance of the new POWERRAIL binding models, the toe and heel guides can be exchanged or retrofitted. These features ensure that steady function is guaranteed, even after massive use in rental.

Art.No. – 162950 Play Compensator PR TOE ABS

Art.No. – 162955 Play Compensator PR TOE AFS

Art.No. – 162951 Play compensator PR HEEL

To change the inserts just slide toe and heel off the rails and replace them with new ones (Pict. 162). Lubricate the new inserts with grease, clean the track, and slide toe and heel back in its original position on the rails.



HEEL INSERTS FOR RACE PRO HEEL

Open the heel-locking lever and pull off the heel backwards. Remove the inserts and mount the new ones - Art. No. 162803 (Pict. 163).



Lubricate the new inserts with grease, clean the heel track, and slide the heel back into the track. Lock the locking lever into the same position it was before.

7. LONG & SHORT SCREWS

Junior Bindings (DIN 7 or 7.5) are delivered with screws for skis, groups G3 & G4 (penetration depth 6 mm). If they are mounted on skis, groups G1 & G2 then the screws have to be replaced with longer screws. (penetration depth 8 mm).

8. TAPPING

ELAN recommends tapping the drilled binding holes of any ski before mounting. Of course, there is a never ending discussion among the mechanics if this is really necessary. But the pros are convincing:

- smooth and easy mounting
- reduced risk of stripping a screw
- same momentum adjustment of the screwdriver regardless of the ski material
- increased mounting quality/precision
- fewer pull outs.

9. TEMPLATE "ADAPTER SET"

Compatible to all Templates. By using the template Adapter Set (Art. No. 162569) the mounting range of your template can be adapted depending on how you position the adapters on the drill template.

WARNING: Avoid dropping of the template. The clamping jaws could be damaged.

YOU HAVE 3 POSSIBLE OPTIONS

A. For raised mounting position:

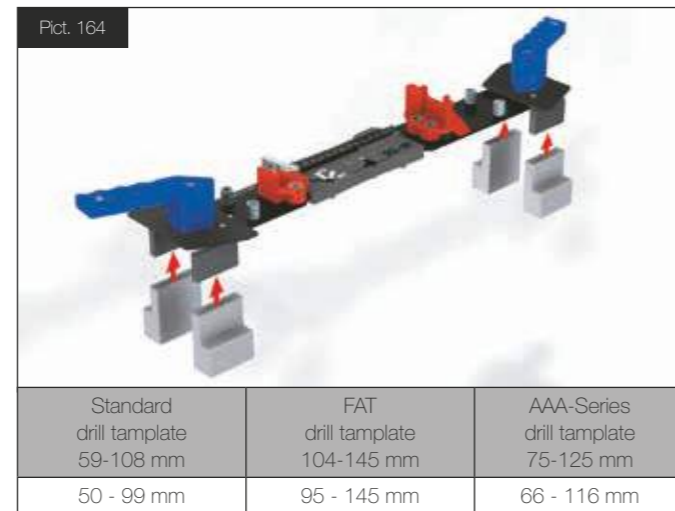

B. For wider mounting position:

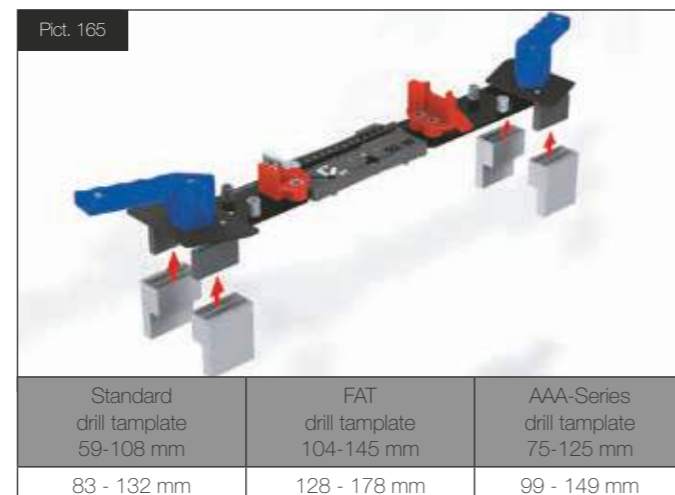

C. For narrower mounting position:

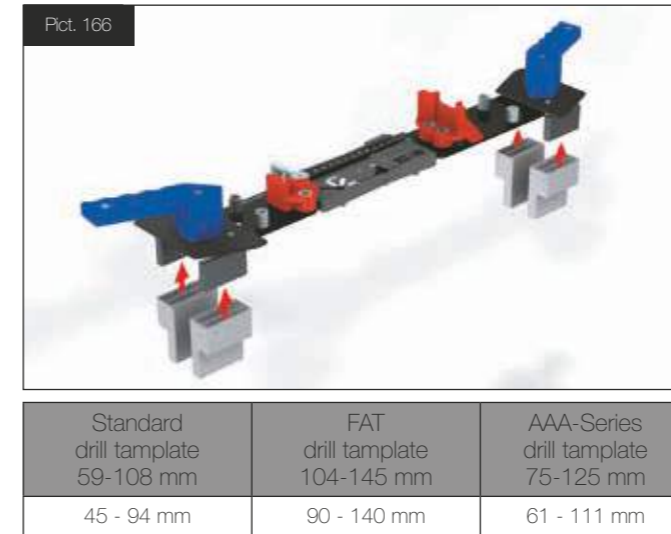

10. RACING (X) - BINDINGS

Certain binding models are produced by each year for the exclusive use of qualified competitors under the supervision of ELAN Technical Specialists.

Racing bindings offer release/retention settings outside of those on the ELAN Release/Retention Adjustment Table, which is based upon ISO/ASTM Safety Standards. These bindings can be serviced under the Dealer Indemnity Program if proper procedures are followed.

We recommend you decline to service them and that you warn against their use unless you have training or experience as a race technician and your customer is a high-level competitor who clearly states a need for these bindings. The customer is to be warned that using these bindings significantly increases the risk of injury due to non-release, and that settings exceeding the recommended range are made at the skier's own risk. If you do service racing bindings, you must follow the same procedures described above for making specific comments on the standard Elan equipment rental form in addition to completing the form on this page to be signed by the skier.

11. CLEANING AND LUBRICATING

Ski bindings need regular maintenance. Proper function is no longer assured if this procedure is not followed periodically.

- Please use only recommended lubrication: 160052 - grease or 162779 - service-grease-spray. Both have the same content, but the grease tube is for more precise lubrication and the spray is suited for spots which are hard to reach with the tube.
- Clean the surfaces with a dry rag or warm water and mild soap.
- Avoid any contact with aggressive solvents or degreasers!
- Don't use cleansers!
- High pressure cleaning is not recommended. It might have the negative side effect of washing away the lubricating films.

11.1. LUBRICATING THE TOE PIECE

ALL SYMPRO/SP TOES

- In case of friction in the track system: Mark the toe position, open the SP hand lever and slide the toe piece off.
- Dry clean the track and the toe guide base gently using a plastic brush.
- Then lubricate the locking mechanism at both sides of the toe guide base.
- Lubricate also both sides of the track guide over the entire length.



11.2. LUBRICATING THE HEEL

ALL RENTAL BINDINGS

- Mark heel position, open the hand lever and slide the heel off backwards. At the SR 10 the guide lock has to be opened with a screwdriver (Pict. 168) to get the binding off.



LUBRICATE

- the edge of the release cam under the heel lug



- both sides of the heel track (inside) over the entire length
- the bearings of the opened hand lever on both sides



- the guiding channel of the release setting adjustment screw.

After finishing the heel lubrication slide on the heel and lock it in its original position.

11.3. ESP 4.5 CA

LUBRICATE

- the contact areas between housing and the release cam on the frontside and the backside as shown in Pict. 171 and 172.
- both sides of the heel track (inside) over the entire length.
- the guiding channel of the release setting adjustment screw (Pict. 171)



After finishing the heel lubrication slide on the heel and lock it in its original position.

11.4. NOT TO BE LUBRICATED

The locking element and the corresponding holes in the heel track should be cleaned but not lubricated. This should prevent dirt accumulation in this area, which could interfere with the ease of handling.

12. TEST YOUR DRILL TEMPLATE

A worn or damaged drill template could create a lot of trouble. Please check your templates periodically:

1. Position the fully extended drill template on a discarded ski.
2. Turn the clamping lever to open the clamping jaws of the mounting template.
3. Position the template properly on the ski so that the boot center marking is aligned with the mounting point described on the ski.
4. Let go of the clamping lever. The template clamps automatically.
5. Drill all the holes.
6. Remove the mounting template and clean the ski.
7. Measure the holes with a slide gauge.
8. The distance of the screw holes to the edge of the ski must be equal for each pair of related holes. The deviation must not be more than 1 mm.
9. Repeat the test, if greater deviations occur.
10. The mounting template must be discarded if greater deviations occur again!

13. REPAIR OF DAMAGED MOUNTING HOLES OR BROKEN SCREWS

For repairing damaged holes, we suggest our special "Repair Set" – Art. No. 162127. It consists of a hollow drill bit and plastic inserts (Pict. 173).



You can extract broken screws too. Remove the binding from the ski. Drill with the hollow drill through the bushing of the appropriate drill template and drive in the plastic insert. Mount the binding again.



14. SEALING OLD MOUNTING HOLES

For sealing old holes you can use wood- or plastic plugs (Art. No. 160857), if not otherwise specified by the ski manufacturer.



MOUNTING TROUBLESHOOTING (INCLUDING RENTAL)

Problem	Possible Reason	Solution
Difficulty when stepping in	Non-standard boot sole	Test and select a new boot
	Forward pressure too high	Readjust according to instructions
	Brake jams	Clean, lubricate or replace
Brake does not retract	Obstruction under the brake	Remove, clean, lubricate
	Brake arm bent	Replace brake
	Ski obstructs brake	Replace the standard brake with a wider brake, accordingly to the ski width.
Boot fails pre-season test	Low-quality boot material	Replace boot
	Excessive wear or contamination	Clean, repair or replace boot
	Reference binding worn	Recheck reference binding with a boot that has passed
	Boot does not meet standard	Replace boot
	Improper use of testing device	Check calibration and operating technique
Units outside of the In-Use range and outside the inspection range	Excessive boot sole wear or contamination	Clean, repair or replace boot
	Inadequate binding service/lubrication	Conduct recommended maintenance every 15–20 days of use
	Improper use of testing device	Check calibration and operating technique
SINGLE CODE on binding interferes SINGLE CODE on boot	Incorrect template adjustment used when mounting	Set template to proper length and remount heel
	Incorrect track guide scale chosen for given mounting position	Choose binding according to given mounting position

Problem	Possible Reason	Solution
SYMPRO toe wobbles in this track	Toe locking lever not properly engaged in locking holes	Remove toe, clean track. Be sure toe piece locks into place
FREEFLEX drill pattern not fitting	Toe / equalizing bridge in wrong position	Dismount, place toe in correct position
	Drill template not locked	Re-adjust, drill new holes
Heel slides backwards when customer steps in	Rear locking lever not fully closed or boot length exceeds adjustment range	Lever should fully engage locking teeth in slots on track or boot sole length exceeds binding range
Binding fails pre-season test: release values too high or too low	Reference boot contaminated or worn	Clean or replace boot as indicated by clean vs. lube test result
	Forward pressure set incorrectly	Re-adjust to ELAN recommendations
	Incorrect or off -center-mounting	Check the template. Remount using template correctly
	Improper use of testing device	Check calibration and operating technique
Adult bootsole does not fit into Junior toe lug	Boot sole exceeds the standard tolerance	Clean AFD and boot sole, check standard tolerance, change boot
RACE PRO or POWERRAIL heel wobbles in the track	Heel glide inserts worn	Remove heel and replace plastic heel guides



DEALER SERVICE INFORMATION

DEALER SERVICE

ELAN CERTIFICATION REQUIREMENTS

This section must be read, and thoroughly understood, prior to completion of ELAN's Employee Training Documentation Form and viewing the current ELAN Technical Videos.

At ELAN we realize that the quality added to our products in your shop is every bit as important as the quality we build in at the factory. The ELAN Retailer Indemnity program, which includes in depth technical training, is a key element of maintaining consistent quality.

TECHNICAL INFORMATION

Procedures for installation, release/retention adjustment, testing, troubleshooting and record keeping should always be taken from the current season's ELAN Technical Manual.

EMPLOYEE TRAINING

This manual provides a depth of information unprecedented in the industry; it is here to help you fulfill the shop's responsibility to bring new employees to a basic level of competence. It also addresses our desire to provide information specific to selling, installing, and function checking, and maintaining ELAN products. Last but perhaps most important, we produced it to help you understand why Elan represents the state of the art in bindings. We hope you will use it as part of a well-planned and professional employee training program which goes far beyond properly installing bindings. Done well it will translate into consistent quality and the high level of satisfaction your customers deserve. Look at it as one of the first steps in your Total Quality Management program.

NOTE: Hands on training is the best training – An ideal task that can be incorporated into the training is preseason testing. This will give your trainees hands on experience operating a testing device and adjusting ski/boot/ binding systems. Other tasks, such as routine rental maintenance, can also be done during the training period.

SHOP REQUIREMENTS

Each retail location must have:

- A current Authorized Retailer Agreement on file with Elan USA Corp / ELAN Sports, Inc. CANADA
- A current ELAN Binding Indemnification Agreement on file with Elan USA Corp / ELAN Sports, Inc. CANADA
- At least one ELAN Certified Technician employed per location.
- The required equipment for installing and testing ELAN bindings. All Agreements and Certifications must be valid for the current season.

SERVICE SHOP TOOLS

This list is the bare minimum a shop can survive with.

- Tape Measure
- ELAN (Tyrolia) Templates:

Drill template 92 W or FAT (Blue)
Drill template AMBITION (Brown)
Drill template ADRENALIN (White)
Drill template Attack DEMO (Turquoise)
Drill template 94 W (Violet)
Drill template Raceplate WCR
Drill template Raceplate WCR SHORT / TEAM
Drill template RACEPLATE 09 (Black)
Drill template SP 2003 W (Red)
Drill template SR 2003 W (Yellow)
Drill template Freeflex Demo
Drill Template Tour PT

- Variable speed, reversible electric drill
- Step Drill Bits:
 - 4.1 Ø x 9.0 mm
 - 4.1 Ø x 7.0 mm
 - 3.5 Ø x 9.0 mm
 - 3.5 Ø x 7.0 mm
- Tap, Tap Brace and Tap Guide
- Pozidrive No. 3 screwdriver
- Torx-Bit TX25/50 -1/4inch
- Large slot screwdriver
- Current ELAN retention/release adjustment table
- Approved mechanical testing device
- Screw extractor
- Tap extractor
- Hole plugs, plastic & wood
- Threaded plastic ski inserts
- Chisel
- Hammer

CREATING AN INFORMED CONSUMER

Customers, whether rental or retail, come to your shop with all levels of knowledge. The range extends from true experts who really know the sport and their equipment needs, to never-ever skiers who know they must rely totally on your expertise.

A key role played by a good shop, and a requirement in the U.S. and Canada under the "ELAN Retailer Indemnity Program", is providing information, guidance and instruction to all customers.

SPECIFICALLY THIS MEANS

- Providing product and suitability information to help customers make an informed choice of which equipment models are right for them. The amount and type of advice given will naturally be different for each customer.
- The shop's responsibility is to be sure that each product sold or serviced is appropriate for the needs of its user.
- The shop must provide accurate information about the nature of the sport, and what equipment can and cannot do. Inform customers that there are risks inherent in the sport of skiing that no binding can

protect against. It is imperative that each customer be informed that there are limitations to the protection their equipment can afford and injuries can and do occur in the normal course of skiing and what to do to avoid them to the extent possible.

- Under no circumstances should you make any warranties or assertions about the customer's safety on the hill. Speaking simply, no binding is "absolutely safe". Well-designed shop record forms address the disclosure and agreement subject very directly and professionally. Use them to your advantage by making sure customers read and understand the form before signing it.

The following points must be explained to all customers (rental or retail) before they leave the shop with their equipment (consumer awareness checklist):

- Go through your workshop ticket and fully explain each task that has been performed by the shop.
- Explain how to use bindings and equipment. Let customers put on their boots and step in and out of the binding if needed.
- Remind skiers to clean their boots and bindings each time before stepping in. Tell them that they should always walk through clean snow before entering the bindings.
- Deliver the "Instructions for Use" booklet to retail customers. It is an important document and is essential for warranty service.
- Advise the customers to return to your shop periodically for maintenance and a system inspection. The service interval is once each 15–20 days of skiing, or annually, whichever comes first. Failure to adhere to this service interval will void the ELAN Limited Warranty.
- Recommend care in transport: heels closed, bindings covered.
- Recommend care in storage: dry, moderate temperature, heels closed, and boots not in bindings.
- Explain that bindings and boots must be kept clean for optimal function.
- Skiers should make a visual inspection of their system before each use, including the AFD pad which should be checked for wear, damage or loss. It is also wise to visually verify the release indicator value.

NOTE:

- The workshop ticket must be read, initialed and signed by the customer. If the customer is a minor, his or her signature should be obtained, along with that of the parent or guardian. If a parent or guardian is not available, the equipment should only be released if the proper signatures have been obtained.
- Remember, the customer's signature is required in two places under the terms of the ELAN Retailer Indemnity Program. In order to avoid misunderstandings with the customer, please inform them of this requirement when equipment is taken in for service.
- If the customer is not the end user, every attempt should be made to make certain all aspects of the system are explained to the user, and to obtain his/her signature on the workshop ticket.

ABOUT TESTING

Testing is required for all ELAN retail and rental systems as specified in this manual. Many consumers view system testing as a valuable service provided by professional shops. They expect their equipment will be properly tested, and are willing to pay for it. On the other hand, some customers may be reluctant to accept any additional costs. They may be especially resistant to charges made by the shop for testing and inspections of equipment which is being serviced. Following are some communication techniques that have been found to be helpful:

- Post your shop's testing policy. A clear statement, prominently displayed, will reassure customers that they're all receiving the same

treatment. Consider a text similar to the following: "Industry standards have defined shop testing procedures for your ski/boot/binding system. We're proud to offer this service since it is in your best interest. While even the best ski equipment cannot eliminate all risks of injury, we strive to maximize your enjoyment of the sport by verifying the settings and function of your equipment. The extra time and expense of system testing will pay off for you in a better and safer skiing experience."

- Make your service shop a showplace. Place your testing bench in a prominent location. Many customers like to know what kind of work you're doing for them. If you get a question, offer to let the skier watch.
- Proudly display diplomas and certificates received by your mechanics. Make their expertise known to your customers.
- Above all, don't apologize for testing. It's a valuable and necessary service well worth the cost.

ABOUT TESTING DEVICES

ASTM and ISO have defined specifications for ski equipment system testing devices. Only those devices that meet these recognized performance standards should be used to test systems that include ELAN bindings. You should make it the responsibility of your testing device supplier to verify that their device fulfills all ASTM/ISO requirements. Each device has its own unique features and some will fit your shop's needs better than others. Therefore, we can't recommend a single device as universally "the best".

The following points, however, can be used as a guideline to getting the most out of your choice:

- Training is very important in the use of any device. Read the instructions thoroughly, and practice!
- To insure reproducibility from one technician to another a "Multiple Operator Reproducibility Test" should be performed by all users of the testing device. This simply requires that all technicians join in a "round robin" exercise where each tests the same system with the same test device. The goal is to verify that the testing techniques are the same and that all test results are comparable. Speak with your testing device supplier for the details on how to conduct this program.
- Beware of "black box" calculations that may be performed by some electronic testers, the calculations performed to arrive at an indicator value or determine an appropriate Torque Range could be based on old standards. Check the current ELAN Adjustment Chart for applicable values.
- Periodic calibration of these devices is important, and this information should be documented in your shop records.
- Most important, never blindly trust the values given by any test device. This is just one tool to use in your evaluation of a complete release/retention system.

MAINTENANCE

Inform every customer of the simple fact that periodic maintenance is needed. If they don't bring their gear back for regular function checks, it is unreasonable to expect it to work as designed. Studies have shown that binding systems which have not been properly maintained have serious injury rates very much higher than those which have. Following this simple, logical guideline is the single most effective way to decrease serious injuries dramatically. Have the system serviced by an ELAN certified technician once each 15–20 days of skiing, or annually, whichever comes first.

DEALER SERVICE

ELAN DEALER INDEMNITY PROGRAM

Today's equipment may help reduce certain hazards involved in the sport, but the risk of injury remains. The ELAN Retailer Indemnity Program is designed to help formalize service procedures and minimize the risks to both you and your customer.

Under the plan, ELAN will defend and indemnify the Authorized Retailer in bodily injury claims when certain conditions are met, including following all ELAN required procedures.

The program benefits are not without limits, indemnification is not insurance, and it does not eliminate the need for a shop to have adequate insurance of its own. But, for the shop willing to make the investment in doing a quality job as an assembler of equipment systems from components, it is a key element in their Risk Management plan.

This is only a summary of the ELAN Retailer Indemnify Program; complete requirements are listed in the current ELAN Binding Indemnification Agreement. You should read this Agreement carefully.

Retailer benefits under the terms of the plan are based, in part, on the adequacy of the service work performed by the mechanic. For this reason, thorough employee training is essential. This manual, tech videos and technical seminars are presented by ELAN to help define appropriate shop procedures.

It is the responsibility of the ELAN Authorized Retailer to see that all technical and product information materials provided by Elan USA Corp / ELAN Sports, Inc. Canada are ordered and available in their shop. This should be done with the aid of your ELAN Representative while placing your ELAN preseason binding order.

Competition bindings are intended only for high level competitors who have special requirements that do not apply to recreational skiers. Any transaction involving competition bindings must include a warning and assumption of risk agreement signed by the skier that acknowledges the increased risk of using this equipment. See the section in this manual regarding Use of Non-Recommended Settings.

THE ELAN RETAILER INDEMNITY PROGRAM APPLIES ONLY TO THE FOLLOWING BINDINGS:

SEASON 14/15

ER 17.0 FREEFLEX PRO, ER 11.0 FREEFLEX PRO, ER 11.0, FUSION, ELX 14.0 FUSION, ELX 12.0 FUSION, ELX 12.0 FUSION Wide88, ELX 11.0 FUSION, ELW 11.0 FUSION (Lady), EL 11.0 FUSION, EL 10.0 FUSION, ELW 10.0 FUSION (Lady), EL 10.0 QT, EL 10.0 QT Wide90, ELW 9.0 QT (Lady), EL 7.5 AC QT, EL 7.5 AC QT Wide90, EL 4.5 AC QT, EL 4.5 AC QT Wide84, EFS 18.0 w/o brake, EFS 12.0 w/o brake, EFS 10.0 Wide90, EL 10.0, ADRENALIN 13 w/o Short, ADRENALIN 13 w/o Long, Attack 16 w/o brake, Attack 13 w/o brake, Attack 13 DEMO w/o brake, AMBITION 12 w/o brake, AMBITION 10 w/o brake, EL 7.5 AC, EL 4.5 AC, ESP 10.0 w/o brake, ESP 10.0, ESP 7.5 AC, ESP 4.5 AC, ESR 10.0

SEASON 15/16

ER 17.0 FREEFLEX PRO, ER 11.0 FREEFLEX PRO, ER 11.0, ELX 14.0 FUSION, ELX 12.0 FUSION, ELX 12.0 FUSION WB95, ELX 11.0 FUSION, ELW 11.0 FUSION (Lady), EL 11.0 FUSION, EL 10.0 FUSION, ELW 10.0 FUSION (Lady), EL 10.0 QT, EL 10.0 QT WB90, ELW 9.0 QT (Lady), EL 7.5 AC QT, EL 7.5 AC QT WB90, EL 4.5 AC QT, EL 4.5 AC QT WB84, EFS 10.0 WB90, EL 10.0, ADRENALIN 13 w/o Short, ADRENALIN 13 w/o Long, Attack 18 (X) w/o brake, Attack 16 w/o brake, Attack 13 w/o brake, Attack 13 DEMO w/o brake, Attack 11 w/o brake, AMBITION 12 w/o brake, EL 7.5 AC, EL 4.5 AC, ESP 10.0 w/o brake, ESP 10.0, ESP 7.5 AC, ESP 4.5 AC, ESR 10.0. Racing (X) Word Cup models: ER 20.0 FREE FLEX+, ER 16.0 FREE FLEX+, ER 20.0 FREE FLEX PRO, ER 16.0 FREE FLEX PRO, ER 20.0 FREE FLEX EVO, ER 16.0 FREE FLEX EVO

SEASON 16/17

ER 20.0 X FREEFLEX EVO RD, ER 16.0 X FREEFLEX EVO, ER 17.0 FREEFLEX EVO, ER 14.0 FREEFLEX EVO, ER 11.0 FREEFLEX EVO, ER 11.0, ELX 14.0 Fusion, ELX 12.0 MBS Fusion, ELX 12.0 Fusion, ELX 11.0 Fusion, EL 11.0 MBS QUICK TRICK, EL 10.0 QUICK TRICK, ELS 11.0 SHIFT, EL 11.0 SHIFT, EL 10.0 SHIFT, EL 9.0 SHIFT, ELW 11.0 SHIFT (Lady), ELW 10.0 SHIFT (Lady), ELW 9.0 AC SHIFT (Lady), EL 7.5 AC SHIFT, EL 4.5 AC SHIFT, EL 10.0, Attack² 18.0 X AT W/O BRAKE, Attack² 16 AT W/O BRAKE, Attack² 13 AT W/O BRAKE, Attack² 13 AT DEMO W/O BRAKE, Attack² 11 AT DEMO W/O BRAKE, Attack² 11 GW W/O BRAKE, AMBITION 12 AT W/O BRAKE, EL 7.5 AC, EL 4.5 AC, ESP 10.0, ESP 10.0 Track, ESP 7.5 AC Track, ESP 4.5 AC, ESP 4.5 AC Track, ESR 10.0

SEASON 17/18

ER 20.0 X FREEFLEX EVO RD, ER 16.0 X FREEFLEX EVO, ER 17.0 FREEFLEX EVO, ER 14.0 FREEFLEX EVO, ER 11.0 FREEFLEX EVO, ER 11.0, ELX 14.0 Fusion, ELX 12.0 MBS Fusion, ELX 12.0 Fusion, ELX 11.0 Fusion, EL 11.0 FUSION, 11.0 MBS QUICK TRICK, EL 10.0 QUICK TRICK, ELS 11.0 SHIFT, EL 11.0 SHIFT, EL 10.0 SHIFT, EL 9.0 SHIFT, ELW 11.0 SHIFT (Lady), ELW 10.0 SHIFT (Lady), ELW 9.0 AC SHIFT (Lady), EL 7.5 AC SHIFT, EL 4.5 AC SHIFT, EL 10.0, Attack² 18.0 X AT W/O BRAKE, Attack² 16 AT W/O BRAKE, Attack² 13 AT W/O BRAKE, Attack² 13 AT DEMO W/O BRAKE, Attack² 11 AT DEMO W/O BRAKE, Attack² 11 GW W/O BRAKE, AMBITION 12 AT W/O BRAKE, EL 7.5 AC, EL 4.5 AC, ESP 10.0, ESP 10.0 Track, ESP 7.5 AC Track, ESP 4.5 AC, ESP 4.5 AC Track, ESR 10.0

SEASON 18/19

ER 20.0 X FREEFLEX EVO RD, ER 16.0 X FREEFLEX EVO RD, ER 17.0 FREEFLEX EVO, ER 14.0 FREEFLEX EVO, ER 11.0 FREEFLEX EVO, ER 11.0, ELX 14.0 GW FUSION, ELX 12.0 GW FUSION, ELX 11.0 GW FUSION, EL 11.0 GW FUSION, EL 10.0 GW QUICK TRICK, ELX 11.0 GW SHIFT, ELS 11.0 GW SHIFT, EL 10.0 GW SHIFT, EL 10.0 GW SHIFT, EL 9.0 GW SHIFT, ELW 11.0 GW SHIFT (LADY), ELW 10.0 GW SHIFT (LADY), ELW 9.0 GW SHIFT (LADY), EL 7.5 AC SHIFT, EL 4.5 AC SHIFT, EL 10.0, ATTACK² 18.0 X AT W/O BRAKE, ATTACK² 13.0 AT W/O BRAKE, ATTACK² 13.0 AT DEMO W/O BRAKE, ATTACK² 11 AT DEMO W/O BRAKE, ATTACK² 11 GW W/O BRAKE, AMBITION 12 AT W/O BRAKE, EL 7.5 AC, EL 4.5 AC, ESP 10.0 GW, ESP 10.0 GW TRACK PM, ESP 7.5 AC TRACK PM, ESP 4.5 AC, ESP 4.5 AC TRACK PM, ESR 10.0

SEASON 19/20

ER 20.0 X FREEFLEX EVO RD, ER 16.0 X FREEFLEX EVO RD, ER 17.0 FREEFLEX EVO, ER 14.0 FREEFLEX EVO, ER 11.0 FREEFLEX EVO, ER 11.0, ELX 14.0 GW FUSION, ELX 12.0 GW FUSION, ELX 11.0 GW FUSION, EL 11.0 GW FUSION, EL 10.0 GW SHIFT, ELX 11.0 GW SHIFT, ELS 11.0 GW SHIFT, EL 10.0 GW SHIFT, EL 10.0 GW SHIFT, EL 9.0 GW SHIFT, ELW 11.0 GW SHIFT (LADY), ELW 10.0 GW SHIFT (LADY), ELW 9.0 GW SHIFT (LADY), EL 7.5 AC SHIFT, EL 4.5 AC SHIFT, EL 10.0, ATTACK² 18.0 X AT W/O BRAKE, ATTACK² 13.0 AT W/O BRAKE, ATTACK² 13.0 AT DEMO W/O BRAKE, ATTACK² 11 AT DEMO W/O BRAKE, AMBITION 12 AT W/O BRAKE, EL 7.5 AC, EL 4.5 AC, ESP 10.0 GW, ESP 10.0 GW TRACK PM, ESR 10.0

SEASON 20/21

ER 18.0 X RD FREEFLEX ST, ER 17.0 FREEFLEX ST, ER 14.0 FREEFLEX, ER 11.0 FREEFLEX, ER 11.0, EMX 14.0 GW FUSION X, EMX 12.0 GW FUSION X, EMX 11.0 GW FUSION X, EM 11.0 GW FUSION X, EL 10.0 GW SHIFT, ELX 11.0 GW SHIFT, ELS 11.0 GW SHIFT, EL 10.0 GW SHIFT, EL 10.0 GW SHIFT, EL 9.0 GW SHIFT, ELW 11.0 GW SHIFT (LADY), ELW 10.0 GW SHIFT (LADY), ELW 9.0 GW SHIFT (LADY), EL 7.5 AC SHIFT, EL 4.5 AC SHIFT, EL 10.0, Attack² 18.0 X AT W/O BRAKE, Attack² 13.0 AT W/O BRAKE, Attack² 13.0 AT DEMO W/O BRAKE, Attack² 11 AT DEMO W/O BRAKE, Attack 2 11 GW W/O BRAKE, AMBITION 12 AT W/O BRAKE, EL 7.5 AC, EL 4.5 AC, ESP 10.0 GW, ESP 10.0 GW TRACK PM, ESR 10.0

SEASON 21/22

ER 18.0 X RD FREEFLEX ST, ER 17.0 FREEFLEX ST, ER 14.0 FREEFLEX, ER 14.0 FREEFLEX DEMO, ER 11.0 FREEFLEX, ER 11., EMX 14.0 GW FUSION X, EMX 12.0 GW FUSION X, EMX 11.0 GW SHIFT, ELS 11-0 GW SHIFT, EL 9.0 GW SHIFT, ELW 11.0 GW SHIFT (LADY), ELW 9.0 GW SHIFT (LADY), EL 7.5 GW CA SHIFT, EL 4.5 GW CA SHIFT, Attack 17 MN, Attack 14 MN, Attack 11 GW, Attack 14 MN DEMO, Attack 11 MN DEMO, AMBITION 12 MN, EL 10.0 GW CA, EL 7.5 GW CA, EL 4.5 GW CA, ESP 10.0 GW, ESP 10.0 GW TRACK PM, ESR 10.0

SEASON 2022/23

ER 18.0 X RD FREEFLEX ST, ER 17.0 FREEFLEX ST, ER 14.0 FREEFLEX, ER 14.0 FREEFLEX DEMO, ER 11.0 FREEFLEX, ER 11., PROTECTOR 13 GW FUSION X, PROTECTOR 11 GW FUSION X, EMX 14.0 GW FUSION X, EMX 12.0 GW FUSION X, EMX 11.0 GW SHIFT, ELS 11-0 GW SHIFT, EL 9.0 GW SHIFT, ELW 11.0 GW SHIFT (LADY), ELW 9.0 GW SHIFT (LADY), EL 7.5 GW CA SHIFT, EL 7.5 GW CA JRS Brake 78, EL 7.5 GW CA JRS Brake 90, EL 4.5 GW CA JRS Brake 80, Attack 17 MN, Attack 14 MN, Attack 11 GW, Attack 14 MN DEMO, Attack 11 MN DEMO, AMBITION 12 MN, EL 10.0 GW CA, EL 7.5 GW CA, EL 4.5 GW CA, ESP 10.0 GW, ESP 10.0 GW TRACK PM, ESR 10.0

SEASON 2023/24

ER 18.0 X RD FREEFLEX ST, ER 17.0 FREEFLEX ST, ER 14.0 FREEFLEX, ER 14.0 FREEFLEX DEMO, ER 11.0 FREEFLEX, ER 11., PROTECTOR 13, GW FUSION X, PROTECTOR 11 GW FUSION X, EMX 14.0 GW, FUSION X, EMX 12.0 GW FUSION X, EMX 12.0 GW FUSION X (Lock Brake), EMX 11.0 GW SHIFT, EM 11.0 GW FUSION X, PROTECTOR SHIFT 11 GW, PROTECTOR SHIFT 10 GW, ELX 11.0 GW SHIFT, ELS 11.0 GW SHIFT, EL 10.0 GW SHIFT, EL 9.0 GW SHIFT, ELW 11.0 GW SHIFT, ELW 9.0 GW SHIFT, EL 7.5 GW CA JRS, EL 4.5 GW CA JRS, Attack 17 MN, Attack 14 MN, Attack 11 GW, Attack 14 MN DEMO, Attack 11 MN DEMO, AMBITION 12 MN, EL 10.0 GW, EL 7.5 GW CA, EL 4.5 GW CA, ESP 10.0 GW, ESP 10.0 GW TRACK PM, ESR 10.0

SEASON 2024/25

ER 18.0 X RD FREEFLEX ST, ER 17.0 FREEFLEX ST, ER 14.0 FREEFLEX, ER 14.0 FREEFLEX DEMO, ER 11.0 FREEFLEX, ER 11., PROTECTOR 13, GW FUSION X, PROTECTOR 11 GW FUSION X, FUSION X, EMX 12.0 GW FUSION X, EMX 12.0 GW FUSION X (Lock Brake), EMX 11.0 GW SHIFT, EM 11.0 GW FUSION X, PROTECTOR SHIFT 11 GW, PROTECTOR SHIFT 10 GW, ELX 11.0 GW SHIFT, ELS 11.0 GW SHIFT, EL 10.0 GW SHIFT, EL 9.0 GW SHIFT, EL 7.5 GW CA JRS, EL 4.5 GW CA JRS, Attack 17 MN, Attack 14 MN, Attack 11 GW, Attack 14 MN DEMO, ATTACK LYT 11 GW, Attack LYT 11 MN DEMO, AMBITION 12 MN, EL 10.0 GW, EL 7.5 GW CA, EL 4.5 GW CA, ESP 10.0 GW, ESP 10.0 GW TRACK PM, ALMONTE 12 PT, ALMONTE 10 PT, ALMONTE 10 PT DEMO

RETAILER AGREEMENTS AND INDEMNIFICATION AGREEMENTS

Both Agreements must be completed annually. This years Retailer and Indemnification Agreements should already be completed, if not please contact customer service or your sales rep. Completed Retailer Agreements, Indemnification Agreements and Employee

Training Documentation Forms should be received at Elan USA Corp / Elan Sports Inc., no later than December 31, 2024.

SUMMARY OF REQUIREMENTS

These basic requirements help assure that the end product which is delivered to the customer is appropriate.

- Signed, current copies of the ELAN Authorized Retailer Agreement and the ELAN Bindings Indemnification Agreement must be on file with Elan USA / ELAN Sports, Inc. Canada.
- The shop must adhere to 2024/25 ELAN procedures for selection, mounting, adjusting, testing and/or servicing of system components as detailed in this manual.
- The actual ELAN retention/release adjustment, or its equivalent, must be used.
- An ELAN Certified Mechanic must properly mount, inspect, adjust and/or service system components and/or check to make sure all service, adjustments, testing and record keeping was properly completed.
- Mechanics must receive full training, including hands-on practice in the use of system testing devices, as provided by the testing device supplier. A multiple operator reproducibility test should be completed and results documented by the shop each season.
- The shop must maintain records of all retail/rental testing and/or service work for 5 years or for the length of the statute of limitations in the state where your business resides, whichever is longer. Bear in mind that the statute of limitations for minors begins only when they come of legal age.

PAPERWORK REQUIREMENTS

ELAN Retail/Rental Workshop agreements have demonstrated their usefulness in the legal system, and we strongly recommend their use. At the very minimum, records must contain the following information:

- Identification of shop and customer: name, address, phone.
- Date of transaction or work.
- Information on which binding settings are based: skier height, weight, skier type, age, boots sole type and length.
- A full description of the equipment being serviced or rented (skis /boots/ bindings), including but not limited to brand, model, size and serial numbers.
- Skier code, "Initial" binding release/retention settings, and final settings.
- Signed, dated statement from the ELAN Certified Mechanic that all manufacturer's procedures have been completed, and the signature of the mechanic who performed the service (if they are different individuals):
- An agreement dated and signed by the customer, the language of which is substantially similar to the current ELAN form. This agreement must include the following points:
 - User verification of skier information.
 - WARNING that there are risks of injury inherent in the sport of skiing and that the customer is aware of and accepts those risks.
 - DISCLOSURE of the equipment's limitations, that it will not release, retain or prevent injury under all circumstances, and is no guarantee of the user's safety.
 - RELEASE language whereby the user releases the retailer, manufacturer and distributor from liability and damages, to the fullest extent allowed by law.
 - STATEMENT that no warranties of any kind are offered by the shop beyond those explicitly offered by ELAN.

- AGREEMENT that instruction in the use of the equipment has been received, that the skier height, weight, skier type, age, boot sole type and length, as well as the settings on the binding match those on the record form, and that the skier will inspect the system, including the binding's AFD, before each use.
- Signatures by both the customer and ELAN Certified Mechanic are required by for the ELAN Retailer Indemnity Program.

NOTE:

- Any changes in documentation requirements must be authorized in writing by Elan USA. USA. / ELAN Sports, Inc. Canada.
POST-ACCIDENT INSPECTION REPORT (see page 114).

In addition to the above information on the system's performance, fill out a Post-Accident Report when you become aware that an injury has occurred. Keep this document for 5 years or the duration of the statute of limitations for minors, whichever is longer.

IN THE EVENT OF AN INJURY CLAIM

- The retailer must give written notice to Elan USA Corp / ELAN Sports, Inc. CANADA. of any bodily injury claim (which includes any lawsuit, letter from a lawyer, statement from the customer, their family or others alleging wrongdoing or seeking compensation, or other similar circumstances), on or before the tenth calendar day from the date on which the retailer first received notice of any claim for which indemnity will or could be sought under the applicable ELAN indemnity agreement. The retailer must also notify his/her own attorney and insurance carrier, and must cooperate with Elan USA Corp / ELAN Sports, Inc. CANADA. and respond to their requests for information, documents and other materials.
- In the event of an injury involving ELAN equipment (whether or not a claim has been made), a Post-Accident Report must be completed and retained to the extent information and the equipment are available to the retailer. If the entire system is not available for testing that fact should be noted and all available information such as equipment condition, visual indicator settings, and any equipment abnormalities, as well as pertinent statements from the customer or witnesses, should be recorded.
- When filling out a Post-Accident Report, record the numerical test results, not just pass/fail. Fill out the report accurately and completely, without editorial comment. Use quotes if you are taking down exactly what someone has told you. If part of the information called for in the report is unavailable, enter "not available" or another reason why the information has not been written down. This document may become part of a legal case years later, when personal recollections are not as strong, so it is important to collect and record accurate and complete information while it is fresh.
- In a rental situation where there has been a reported injury but no claim has been made, equipment may be returned to service upon passing a post-accident test/inspection. If a claim is received regarding this equipment, however, any involved equipment must be set aside and preserved intact, even if time has passed and the equipment was used by others after the incident.
- Skiing is a hazardous sport with inherent risks of injury, and not every injury or accident constitutes a "claim" that must be

reported within ten days, but the following is a non-exclusive list of the situations that should be handled as a claim that requires reporting to ELAN and setting aside the involved equipment:

- Filing or receipt of any lawsuit or any preliminary notice regarding a legal action;
- Any letter, call or other communication from a lawyer's office, even if the lawyer says that they are simply "investigating" an incident;
- Statements by the customer, family, friends or representatives that any equipment was defective or broken, that it caused someone's injury, - that the retailer was at fault, or that the retailer or manufacturer should pay; or
- An incident that has involved investigation by law enforcement authorities, news reports, or other circumstances that would cause a reasonable person to believe that a legal claim is likely.
- Read the applicable ELAN indemnity agreement for full details regarding claims, indemnity and related matters.

NOTE:

ELAN reserves the right to deny indemnity if ELAN requirements are not fulfilled. Strict compliance by the dealer with all requirements, as stated in the ELAN-Binding Indemnification Agreement, is a condition precedent to favorable consideration of a request for indemnity.

This is only a summary. The precise requirements of the ELAN-Binding Indemnification Program are contained in your ELAN-Binding Indemnification Agreement.

DEALER SERVICE

INSTRUCTIONS OF USE

For the proper performance, storage and maintenance of your ski, you must carefully read the following instructions.

Each and every ski needs to be tuned properly and regularly to maintain its performance and safety. Tuning is done on industrial machinery and cannot be copied manually.

Only certified ELAN ski mechanics with knowledge about the handling of service machines should service the skis, set and adjust skis with the correct tools, perform proper binding installation and explain the use and the maintenance of your ski system.

The ELAN skis should only be used with bindings and boots that conform to accepted international standards.

Bindings should be mounted, adjusted and maintained only by certified ELAN ski mechanics in accordance with the manufacturer's specifications. Proper binding installation is essential for the optimal performance of the product. Improper settings or maintenance may increase the risk of an injury.

Continued use of the skis will create wear and tear on the ski running bases and ski edges. Have your system (skis, boots and bindings) checked, tested and serviced by a certified ELAN ski mechanic, with proper mechanical tools, annually or after every 15 to 20 days of use, whichever comes first. In case the skis do not have the proper service for repairing damage, that could eventually result in delamination, humidity penetrating the wood core, or rust on the inside section of the steel edges of skis.

Skiing is a hazardous activity. The sport of skiing and the use of ski equipment involve a risk of injury to any and all parts of the body. Those dangers are inseparable even from a properly made product. Skiing requires physical preparation, technical skill and caution.

Using skis by children should be done only under child care supervision of certified ski instructor.

Use caution when handling the skis as ski edges are sharp and dangerous.

Use ski bag to protect your skis.

Store skis in a dry place at room temperature, not exposed to direct sunlight or direct sources of heat. Storing of wet skis in unsuitable rooms can result in rust on the steel edges which can again result in destruction, or delamination.

The ski size should not be in discrepancy between the skier's weight and body height and the chosen ski design.

The skis are designed for certain loads only, and the skier is responsible for any excessive force used. The skier must use the proper skiing technique and to avoid shock or overstress skis, which could result in delamination and breakage. The skier should not damage the skis (Striking with tails against hard surface to remove the snow, striking the two skis together (while going up with the lift, as well as during skiing down) scratches). The skis are designed for skiing on snow which is why the skier must avoid shocks against rocks and other hard objects.

- Always ski in control and stay within your ability.
- Chose slopes and conditions for skiing carefully.
- Follow posted warnings and instructions at the ski area.
- Do not ski alone or when you are tired.
- Do not ski while under the influence of alcohol or drugs.
- Familiarize yourself with slopes and possible obstructions before skiing.
- Take lessons from a qualified professional to improve your skills.
- Remove snow and dirt clinging to your skis, boots and bindings before stepping in.
- Make sure that your clothing does not affect to the ski binding system or skis.

Each country could use different ski safety rules of conduct. The customer must inform himself/herself about those various codes of conduct. Keep strictly to the regulations that are in force in the ski resort.

FIS RESPONSIBILITY CODE OF CONDUCT IN SKIING:

1. Respect for others. A skier must behave in such a way that he does not endanger or prejudice others.
2. Control of speed and skiing. A skier must move in control. He must adapt his speed and manner of skiing to his personal ability and to the prevailing conditions of terrain, snow and weather as well as to the density of traffic.
3. Choice of route. A skier coming from behind must choose his route in such a way that he does not endanger skiers ahead.
4. Overtaking. A skier may overtake another skier above or below

and to the right or the left, provided that he leaves enough space for the overtaken skier to make any voluntary or involuntary movement.

5. Entering, starting and moving upwards. A skier entering a marked run, starting again after stopping or moving upwards on the slopes must look up and down the slopes that he can do so without endangering himself or others.
6. Stopping on the piste. Unless absolutely necessary, a skier must avoid stopping on the piste in narrow places or where visibility is restricted. After a fall in such a place, a skier must move clear of the piste as soon as possible.
7. Climbing and descending on foot. A skier either climbing or descending on foot must keep to the side of the piste.
8. Respect for signs and markings. A skier must respect all signs and markings.
9. Assistance. At accidents, every skier is duty-bound to assist.
10. Identification. Every skier and witness, whether a responsible party or not, must exchange names and addresses following an accident.

DEALER SERVICE

LIMITED WARRANTY AND LIMITATION OF LIABILITY

In the case of direct sales from the ELAN web shop, ELAN itself warrants, otherwise ELAN's authorized distributor in the country in which this product was first sold at retail, warrants to the first retail purchaser or user, that this product shall be free from defects in materials and workmanship at the time of purchase. This limited warranty, as well as any implied warranty, shall expire two years from date of the initial retail purchase (or in the case of online purchases, two years from the date of delivery to the first retail purchaser). For warranty service, the product must be returned at your own expense, together with the proof of purchase, to the following contact persons: (i) to the ELAN specialist dealer from whom the product was purchased or (ii) in the case of direct purchases in the ELAN web shop and (iii) if the retailer from whom the product was originally purchased no longer exists, is based in another country or can no longer be reached, to one of the official ELAN customer service centers listed on the ELAN website.

This warranty only covers defects that existed at the time of purchase, all other damage and defects are legally excluded (including but not limited to damage caused by improper handling, unprofessional assembly, non-compliance with the instructions for use, incorrect adjustment, insufficient maintenance and care, incorrect use of the product, cosmetic issues that do not affect function, or normal wear and tear). All wearing parts, coatings and printing are also excluded from the warranty. Your claim from a possible warranty obligation is limited to repair or replacement of the ski binding or parts thereof at our discretion or at the discretion of the specialist retailer. Unless mandatory law obliges ELAN to provide compensation, ELAN rejects any liability for damage or consequential damage from the use of the ski binding, regardless of whether such a claim is for property damage with the exception of the ski binding itself, failure in relation to the use of the ski or boots, or another asset or lost profit. To the extent permitted, this warranty extends only to the first retail purchaser and may not be transferred or assigned. ELAN's liability and warranty obligations are exclusively limited to the obligations described here, insofar as mandatory law does not conflict with this. ELAN's obligations under any warranty shall be limited, to the greatest extent allowed by law, as provided in this Limited Warranty. Some states do not allow limitations on implied warranties or on certain damages or remedies, so some or all of these limitations may not apply to you. You may therefore also have other rights depending on the national or state laws and regulations that apply to you.

SERVICE UNDER THE ELAN WARRANTY

Products requiring service under the terms of the warranty should be dealt with as follows:

- Send the complete binding set to the authorized distributor where evaluation will be made and warranty action taken if required.
- If a clear warranty situation exists, and the shop wishes to replace the pair of bindings products out of stock for a customer, the shop may do so after the approval of the ski warranty department of your ELAN distributor.
Be sure to check suitability and mounting hole pattern before making a change of model.

- When possible, the replacement should be of the same model as the returned product.
- If the same model is not available, the shop should contact the authorized ELAN distributor warranty department for authorization before a more expensive model is selected for replacement.
- If a replacement is made from retailer stock, the complete binding set should be returned to the authorized ELAN distributor as soon as possible.
The packing list must clearly state which model was used for replacement.
- The "Instructions for Use" booklet (warranty), and proof of purchase must accompany all products returned for consideration.
- No credits will be issued.
- The authorized ELAN distributor reserves the right to deny replacement to the retailer if the alleged problem is not verified or if products are returned without the "Instructions for Use" booklet and proof of purchase.
- Replacement bindings are covered by the warranty stated above.
- Any bindings returned to the authorized ELAN distributor due to inappropriate release values (i.e. values which fall outside the "In-Use" tolerance range on the current ELAN Adjustment Chart) must be accompanied by a completed System Performance Report. The report form is printed in this manual; no warranty action will be taken on release value related claims unless this report accompanies the returned bindings.

DISTRIBUTOR ADDRESSES:

Elan USA

93 Etna Rd.
Lebanon, NH 03766
USA
Toll Free: +1 800 425-7462
Phone: +1 (603) 448 3101
Fax: +1 (603) 448 1586

ELAN Sports, Inc.

845 B Rue Tecumseh
Dollard des Ormeaux, H9R 4T8
Canada
Toll Free: +1 800 361 7860
Phone: +1 (514) 421 7871
Fax: +1 (514) 421 7394

DEALER SERVICE

ELAN RISK MANAGEMENT

Indemnification, Insurance, and your liabilities.

INDEMNIFICATION

Indemnification simply means that someone agrees to reimburse you for certain costs. In the ski industry it normally means that provided you fully follow all the manufacturer's requirements and instructions, the manufacturer or distributor will provide a suitable defense against related claims by a customer who claims to have suffered bodily injury as a result of using certain equipment. The key here is you must be able to prove you fully followed all the requirements, properly performed the service and properly represented the product. If you do not, you will not be entitled to a defense or indemnification in the event of a claim.

YOUR PERSONAL LIABILITY

It's simple: If you make a mistake which causes harm to another, you can be held liable for it. Be very careful not to make verbal or any other kind of warranties that extend beyond those made by ELAN. Read the manufacturer's literature and warranties carefully. If a feature or benefit is not mentioned there, don't mention it to the customer.

SHOP LIABILITY INSURANCE

No indemnification program is a substitute for liability insurance. Common sense dictates that you should have an insurance policy that covers your shop and employees for commercial general liability and completed operations. Check with your insurance broker.

SHOP PROCEDURES TO REDUCE LEGAL EXPOSURE

Risk Management has become a very important area in virtually every industry. In today's world it is more important than ever to do as much as possible to recognize how and where we might be exposing ourselves to a potentially serious problem. ELAN has defined proper shop practices and how shop personnel and customers need to interact in order to maximize skiing enjoyment while lowering the risks of liability. If these procedures are followed properly, both the skier and the industry are well served. In the event of a mishap, the programs documentation and record keeping system will provide strong evidence of work performed.

YOUR OBLIGATIONS UNDER THE ELAN RETAILER INDEMNIFICATION PROGRAM

Selecting equipment for your customer.

- Make sure the products are suitable for the skiers height, weight, shoe size and level of ability.
- Always make sure your recommendations are consistent with the manufacturer's product description, representation, and specifications.

BINDING SELECTION

Generally, the idea that top of the line products offer the greatest margins for safety as well as performance and durability is correct – provided the skier fits the weight range of the product. Combine this

knowledge with our weight and ability recommendations for the skier when selecting a binding.

Avoid selling a product with the idea that the customer will grow into it. If a product is not suitable for their current requirements make another choice. Avoid the temptation to do the customer a favor by rewriting the rules. More often than not, all you will do is cause problems.

At the time of delivery to the customer, the bindings must be accompanied by all the informational materials supplied by the manufacturer, i. e., pamphlets, forms, etc. The product must be fully demonstrated to either the intended user or their parent or legal guardian if the child is a minor. This includes instructions on inspecting the low friction surfaces, cleaning the boot sole, entry of the binding, re-entry after releasing on the hill and exiting the system.

You must also explain what care and maintenance the skier or their parent or legal guardian is responsible for, as well as when to return the equipment to your shop for a thorough function check. Routine maintenance is the most cost effective thing a skier can do to protect their wellbeing.

RACING (X BINDINGS)

Certain binding models are produced by ELAN each year for the exclusive use of qualified competitors under the supervision of ELAN Technical Specialists.

Racing bindings offer release/retention settings outside of those on the ELAN Release/Retention Adjustment Table, which is based upon ISO/ASTM Safety Standards. These bindings can be serviced under the Dealer Indemnity Program if proper procedures are followed.

We recommend you decline to service them and that you warn against their use unless you have training or experience as a race technician and your customer is a high-level competitor who clearly states a need for these bindings. The customer is to be warned that using these bindings significantly increases the risk of injury due to non-release, and that settings exceeding the recommended range are made at the skier's own risk. If you do service racing bindings, you must follow the same procedures described above for making specific comments on the standard Elan equipment rental form in addition to completing the form on this page to be signed by the skier.

PIN BINDINGS

If you have completed every step of the mounting and adjusting procedure of the binding, as described in the manual, the binding is part of the HEAD/TYROLIA indemnification program. The Almonte does not comply with the relevant standard, in particular the ISO 13992.

BOOT SELECTION

Make sure the customer's boot choice is consistent with their level of

skiing and that the boots meet all current DIN or ISO standards.

SKI SELECTION

Take care to ensure that the skier's intended use of the chosen equipment is consistent with the manufacturer's recommendation for the skier's weight and level of skiing. This is another area where regular maintenance is critical. It is only logical that skis which help keep your customer upright reduce their overall chance of injury.

COMPLETING THE WORK ORDER WITH THE CUSTOMER

It is critical that certain basic information be included on all shop work orders. While we do not require it, the easiest way to make sure the form you use fits ELANS's requirements is to use ours. Once the customer has selected equipment or described the repair or service to be performed, the technician must ask the customer to complete a portion of the Work Order Form which includes their Name, Address, Phone number, Weight, Height, Age, Sex, and Skiing ability. There are few things more embarrassing than having a customer come in to pick up a pair of skis that could not be serviced due to an improperly filled out form, or an unforeseen technical problem.

The best way to avoid this is to have An ELAN Certified technician thoroughly inspect all incoming work, and check the paperwork. The skier must then sign indicating that they have read, understood, and agreed to the terms of your Rental/ Repair agreement (this agreement must comply with ELAN Dealer Indemnity Program requirements). It is also important that the customer be informed that they will be expected to verify in writing that the indicator settings agree with what is written on the form, and that they have been instructed in the use and maintenance of their equipment, and fully understand it.

This procedure must be completed before the transaction is consummated. Remember, the customer has the option of going to another store if the terms of the contract are not acceptable to them, and under no circumstances should the transaction go any further without their signature. The end user, or their agent, must sign the incoming work order.

SHOP PROCEDURES SUMMARY

For in depth details, see the "Binding Installation" section of this manual.

- Follow ELAN procedures for inspection, mounting, adjustment and maintenance as appropriate.
- Confirm that toe and heel indicator values match those specified on the actual ELAN Adjustment Chart.
- Using a calibrated testing device, according to the manufacturer's instructions for use, "exercise" the binding by releasing it at least once in each direction (clockwise and counterclockwise at the toe, vertically at the heel). Then measures Twist and Forward Lean Torque Values. The middle quantitative value of 3 releases in each direction should be used as the test result.
- Compare Twist and Forward Lean test, results with the System Inspection Ranges on the actual ELAN Adjustment Chart.
- After the equipment is adjusted to the skier's needs according to the manufacturer's standards, the certified technician signs the form indicating that the work has been completed according to the manufacturer's specifications.
- With testing complete, the ELAN Certified Technician must complete and sign the workshop ticket. Be sure the Final Indicator Settings are correctly shown there. The workshop ticket should simply reflect that the system has "passed all tests" or that "all manufacturer's procedures have been completed".

PROCEDURES FOR RETAIL CUSTOMER PICK-UP

When the Retail Customer or his representative comes in to pick-up the equipment, the store employee has a fantastic opportunity to improve the skier's safety and enjoyment, while minimizing the risk of a lawsuit later on. All that's involved is properly informing the skier about the realities of skiing and ski equipment.

- Explain the function and operation of the binding, including a review of the manufacturer's pamphlet.
- Explain the settings that show in the release setting windows and how they were derived by referring to the manufacturer's release adjustment charts.
- Explain how much proper maintenance of the entire system (boots, bindings and skis) can improve their enjoyment and margins for safety. Also make it clear that skiing, like any sport, has its risks, and equipment can not eliminate them.
- For Almonte bindings explain that they do not comply with the relevant standard, in particular the ISO 13992.

Have the customer sign the form again indicating that they have been instructed on the use of the equipment and that they verified that the visual release indicators on the bindings correspond to the manufacturer's recommended settings shown on the work order ticket.

ARCHIVING RECORDS

Should you become one of the few that must defend against a law suit you will soon find out that the very best defense is made of paper. For this reason we recommend that you start out each ski season with a huge, brand new, manila envelope. Over the course of the season you should fill it with the following items:

- Collect a copy of the technical manual for each and every binding, boot and ski on the market. Be especially diligent with those you carry or work on regularly.
- Copies of the manufacturer's customer instruction booklets.
- Technician employment applications. Make sure they have the address of someone who will always know where they can be found.
- This can be invaluable if you need the technician as a witness.
- A listing of all technician certifications and their dates. Keep all certification records as well.
- Copies of any pertinent wall charts, customer information posters, etc.
- A copy of your shop procedures, including training materials, rental and repair shop practices, and binding setting charts.
- Copies of rental fleet test data.

This type of supporting documentation can be tremendously useful for your lawyer.

STORAGE OF FORMS

All forms containing the customer's signature must be kept for a minimum of five years or the term of the statute of limitations in the state where the injury occurs, or your state, whichever is longer. As a practical matter you have no idea where or when your customer may sustain an injury on this equipment.

Naturally, should an injury occur, keep the original form in a safe place until any claims are completely resolved.

Risk Management is really just common sense. Do your job well, have integrity, keep your customers well informed, and keep proper records. Follow these simple suggestions and you will have very few problems.

DEALER SERVICE

USE OF NON-RECOMMENDED SETTINGS

SKIERS REQUESTING SETTINGS NOT RECOMMENDED BY ELAN

The 2024/25 ELAN Release/Retention Adjustment Table is the only adjustment chart recommended for use by ELAN dealers during the 2024/25 season.

Some skiers may request settings different from those in the ELAN Release/Retention Adjustment Table. Most of these concerns can be addressed by following the procedures for reclassifying skier type and for troubleshooting which follow the instructions for using the ELAN Release/ Retention Adjustment Table.

ELAN and the ISO/ASTM standards organizations do not recommend the use of release/retention settings outside of these tolerances, but skiers occasionally may request such settings. ELAN recognizes a skier's right to choose other settings, but if the skier requests settings outside of those derived from the normal procedures for reclassifying skier type and for troubleshooting, the shop may either:

1. Adjust the system to the setting derived from ELAN Release/Retention Adjustment Table and instruct the skier on how to change the setting (if this is done, make a note to this effect on the workshop or rental form), or
2. Adjust the system to the skier's individual request, but only if the technician notes on the workshop or rental form the skier's stated reason for requesting the higher or lower setting.
3. In either case, the customer must verify the request for the higher or lower settings by signing and dating the workshop or rental form by the reason noted next to the setting request, and in addition to making comments on the workshop or rental form, the skier must also read and sign a supplemental warning, release and indemnity agreement identical to the one printed on this page. In such cases, the system will only be indemnified if all other conditions of indemnification are met and the supplemental signed warning, release and indemnity agreement are attached to the completed workshop or rental form.

RACING (X) BINDINGS

Certain binding models are produced by ELAN each year for the exclusive use of qualified competitors under the supervision of ELAN Technical Specialists.

Racing bindings offer release/retention settings outside of those on the ELAN Release/Retention Adjustment Table, which is based upon ISO/ASTM Safety Standards. These bindings can be serviced under the Dealer Indemnity Program if proper procedures are followed.

We recommend you decline to service them and that you warn against their use unless you have training or experience as a race technician and your customer is a high-level competitor who clearly states a need for these bindings. The customer is to be warned that using these bindings significantly increases the risk of injury due to non-release, and that settings exceeding the recommended range are made at the skier's own risk. If you do service racing bindings, you must follow the same procedures described above for making specific comments on the standard Elan equipment rental form in addition to completing the form on this page to be signed by the skier.

WARNING, LIABILITY RELEASE AND INDEMNITY AGREEMENT FOR NON RECOMMENDED RELEASE/RETENTION SETTINGS OR RACING BINDINGS

I, (name and surname in capital letters)

_____ hereby acknowledge that I have been advised by the _____ rental shop, sales department, etc.) that settings which I have requested for my bindings (Model _____) is not the setting recommended by the manufacturer of the bindings for a skier of my height, weight, age and skier type. I understand and acknowledge that there may be an increased risk of injury or death to me as a result of my own personal preference for these binding settings. To the fullest extent allowed by law, I RELEASE this shop, all manufacturers, distributors, retailers and other providers of this equipment, all persons who service this equipment, the resort and property owners where this equipment is used, serviced or sold, and all of their agents, employees, officers, directors, owners, sponsors and affiliated persons and companies ("Released Parties"), from ANY AND ALL RESPONSIBILITY OR LEGAL LIABILITY for any injuries, damages or death to any user of this equipment, whether caused by NEGLIGENCE or any other cause. I further agree that I WILL NEVER SUE the Released Parties, and that I WILL DEFEND AND INDEMNIFY the Released Parties if any claim or action is pursued for any injuries, damages or death involving the use of this equipment.

If I am using Competition Bindings, such as ELAN (X) bindings, my doing so is based entirely upon my personal decision to use them. Competition bindings are not intended for use by recreational skiers because they have release and retention features that do not comply with national and international safety standards. I understand and acknowledge that competition bindings are made for high level competitors who, based upon their personal experience, have decided that they have special retention requirements that exceed the capabilities of recreational ski equipment and the standards that apply to recreational ski equipment. I understand and agree that any use of this equipment may significantly increase the risk of injury due to non-release or other events, and **I assume all risk of injury or death that may result from using competition equipment.**

I, the undersigned, have read and understand this **liability release and indemnity agreement**, and agree that it is binding upon me, my heirs, family, guardians, administrators, assigns, and legal representatives. If any part of this agreement is held to be invalid or unenforceable, the remainder shall be given full force and effect.

Skier's Signature
(or that of the skier's parent or guardian)

Shop Manager's Signature

DEALER SERVICE CHECKLIST

USED BINDING CHECKLIST

1. Customer concerns
2. Service bulletins – maintenance
3. Suitability
4. Availability – parts/tools/technical info
5. Boot/binding compatibility
6. Compatibility of under-binding options
7. Defects:
 - a) parts – cracked/corroded/missing
 - b) boot contact area – worn/damaged
 - c) boot contact area – contaminated
 - d) screws – missing/protruding
 - e) brake/rollers/AFD – malfunctioning
 - f) positioning/alignment – incorrect
8. Binding to boot adjustments
9. INITIAL ASSESSMENT
10. Tests:
 - a) screw tightness
 - b) antishock travel
 - c) compatibility (if indicated)
 - d) release indicator verification
 - e) accelerated life cycle (with permission)
11. FINAL ASSESSMENT

USED SKI CHECKLIST

1. Customer concerns
2. Service bulletins – tuning requirements
3. Suitability
4. Defects:
 - a) delaminated
 - b) edge pulled out
 - c) cracked side wall
 - d) warped, bent, twisted
 - e) damaged tip / tail protector
 - f) lost camber
5. INITIAL ASSESSMENT
6. Base/edge condition / thickness
7. Base/edge profile
8. FINAL ASSESSMENT

USED BOOT CHECKLIST

1. Customer concerns
2. Service bulletins – fitting requirements
3. Suitability
4. ISO sole dimensions – Adult/Child
5. Sole hardness/material
6. Defects:
 - a) sole – warped
 - b) contact area – damaged/worn
 - c) contact area – contaminated
 - d) shell/liner/buckle – damaged
7. Type/position of foot bed/fitting aids
8. INITIAL ASSESSMENT
9. Fit:
 - a) foot anomalies
 - b) foot/boot size comparison
 - c) foot in boot evaluation
10. Performance adjustments
11. FINAL ASSESSMENT

NOTES:

GLOBAL DISTRIBUTORS

I FEEL
SLOVENIA

ANDORRA

SUNSET
465 Route de la Dranse
74500 Amphion-Les-Bains
T +33 4 50 71 77 23
F +33 4 50 26 10 84
www.sunset-sport.fr
johann@sunset-sport.fr

ARGENTINA

Scandinavian Outdoors SA
Av. Andrés Rolón 1107
(1642) San Isidro
Pcia. Buenos Aires
T +54 11 4707 3000 - Int.: 3175
www.scandinavian.com.ar
amarinac@scandinavian.com.ar

AUSTRALIA

SPORTFACTOR SALES PTY LTD
PO Box 65 -
Oyster Bay NSW 2225
T +61 2 9531 5600
F +61 2 9531 5044
www.sportfactor.com.au
sales@sportfactor.com.au

AUSTRIA

ELAN CENTRAL EUROPE GMBH
Aschheimer Strasse 13
85622 Feldkirchen, Germany
T +43 820 899904
F +49 89 427 17 666
rhofer@ELAN-austria.at

BELARUS

BELADVACOM LTD
2-Shestaja Linija str. 11-15
220013 Minsk
T +375 17 2902456
F +375 17 2902458
info@beladva.com

BENELUX

HANDELSONDERNEMING KUBUS B.V
Watergoorweg 79
3861 MA Nijkerk
The Netherlands
T +31 88 552 5200
www.kubus-sports.nl
info@kubus-sports.nl

BOSNIA AND HERZEGOWINA

PLANETBIKE D.O.O.
Vojvode Stepe Stepanovića b. b.
79000 Prijedor
T +387 52 224 950
F +387 52 224 951
planetb@teol.net

BULGARIA

SPORT DEPOT S.A.
Nikola Koslev str. 8
1421 Sofia
T +359 2 976 4500
F +359 2 976 4545
tzonov@sportdepot.bg

CANADA

ELAN SPORTS INC.
845 B rue Tecumseh, H9R 4T8,
Dollard des Ormeaux - P.Q.
T +1 514 421 7871
F +1 514 421 7394
www.ELANsports.com
info@ELANsports.com

CHILE

INVERSIONES BARPI LTDA
Avenida Las Condes
9038 - Santiago
T +0562 2129901
www.lapicadelski.cl
lapicadelski@lapicadelski.cl

CHINA

BEIJING SNOWELAN
SPORT DEVELOPMENT CO.LTD.
Offices 0112-0126, -
112 AnDeLu Rd.
XiCheng District Beijing 100011
T +86 10 88371007
F +86 10 88371009
snowturbo@126.com

CROATIA

ELAN, D.O.O.
Begunje 1
4275 Begunje na Gorenjskem
T +386 4 53 51 429
F +386 4 53 51 444
www.elanskis.com
bostjan.gaspersic@elan.si

CZECH REPUBLIC

INA SPORT SPOL. S R.O.
Hlavní 729/114
664 31 Lelekovice
T +420 545 422 431
www.inasport.cz
david.holik@inasport.cz

DENMARK

SNOWBIZ AS,
Kjellstadveien 5,
3402 Lier,
Norway
T +47 67 16 20 40
F +47 67 16 20 41
www.snowbiz.no
peter@snowbiz.no

ESTONIA

BUSINESSRENT OÜ/LTD
Tähe 37
Tallinn 11619
ESTONIA
T +372 51 13 650
info@suusad.ee
www.suusad.ee

FINLAND

NEONSUN OY
Puusepänkatu 5
13110 Hämeenlinna
T +358 3 6127 222
www.neonsun.fi
neonsun@neonsun.fi

FRANCE

SUNSET
465 Route de la Dranse
74500 Amphion-Les-Bains
T +33 4 50 71 77 23
F +33 4 50 26 10 84
www.sunset-sport.fr
johann@sunset-sport.fr

GEORGIA

MOGZAU RI LTD
Vaja Pschavela av. 6 block
0186 Tbilisi
T +995 32 390536
F +995 32 390536
info@mogzauri.ge

GERMANY

ELAN CENTRAL EUROPE GMBH
Aschheimer Strasse 13
85622 Feldkirchen
T +49 89 427 17 60
T +49 89 427 17 666
info@ELAN-sport.eu

GREAT BRITAIN

SUNSET
465 Route de la Dranse
74500 Amphion-Les-Bains
T +33 4 50 71 77 23
F +33 4 50 26 10 84
www.sunset-sport.fr
johann@sunset-sport.fr

GREECE

MOUNTAIN EXPERTS
3 Profiti Iliia str.
36100 Karpenisi
T +30 22370 25130
F +30 22370 22626
www.klaoudatos-ski.gr
gklaoudatos@gmail.com

HUNGARY

INA SPORT SPOL. S R.O.
Hlavní 729/114
664 31 Lelekovice
T -437-0181 - F -437-0180
www.tandtsport.hu
toth.etre@tandtsport.hu

ICELAND

SKIDASPORT EHF
Kaupvangsstætti 4
600 Akureyri
Iceland
T +354 8682400
www.skidasport.is
utivistogveid@simnet.is

IRAN

VANAK VARZESH CO.
Gandi Str. 29/6, Vanak Sq. - Tehran
T +98 21 8878 77 83
F +98 21 8878 77 83
iranextremesport@yahoo.com

ITALY

SOCREP S.R.L.
Via Arnaria 13
39046 Ortisei (BZ)
T +39 0471 79 70 22
F +39 0471 79 86 51
www.socrep.it
info@socrep.it

JAPAN

ELAN JAPAN Co., Ltd.
Tomoe Bldg. 2F, 3-3-4 Kanda
Misaki-cho,
Chiyoda-ku
Tokyo 101-0061
T +813 6272 9016
F +813 6272 9018
www.elan-japan.co.jp
genjo@elan-japan.co.jp

KASAKHSTAN

LIMPOPO SPORT CO.
Seifulin, 534 - Almaty
T +7 3272 617265
F +7 3272 617265
limpopo@nursat.kz

LATVIA

GANDRS LTD.
Kalnciems str. 28
Rīga, LV 1046
T +371 67614775
F +371 67614927
www.gandrs.lv
gandrs@gandrs.lv

LEBANON

I.M.C.O. LINE
INTERNATIONAL S.A.R.L.
La Maison du Ski building,
Feytroun highway - Kessenar
T +961 9 958 203
F +961 9 952 036
www.lamaisonduiski.net
issam@lamaisonduiski.net

NORTH MACEDONIA

MEGASPORT
Ul. Kej 1 3 Noemvri bb GTC
1000 Skopje
T +38923115293
F +38923114396
megasportmk@yahoo.com

MOLDOVA

I.I. CAVC-COJOCARI
Str. M. Sadveanu 30-85 -
Chisinau
T +373 22 210050
F +373 22 210050
www.xstyle.md
info@xstyle.md

NEW ZEALAND

KAIMAI SPORTS LTD.
263A Ruahini Road
RD 1 Tauranga. 3171
T +64 021 464 876
F +64 7 543 3475
paul@kaimaisports.co.nz

NORWAY

SNOWBIZ AS,
Kjellstadveien 5,
3402 Lier,
Norway
T +47 67 16 20 40
F +47 67 16 20 41
www.snowbiz.no
morten@snowbiz.no

POLAND

INA SPORT SPOL. S R.O.
Hlavní 729/114
664 31 Lelekovice
T +48 696 597 073
www.inasport.pl
dagmara.krzyzyska@inasport.pl

REPUBLIC OF KOREA

NK COMPANY
#613, Building A, Misa 1st, Hyundai
Knowledge Industry Center
550 Misa-daero, Hanam-si, Gyeong-
gi-do, 12925
T +8210-4104-1989
F +8231-794-0112
jason@nkcompany.co.kr
elan@nkcompany.co.kr

ROMANIA

S.C. WHITE RASNOW INVEST S.R.L.
Str. I.C. Frimu Nr.3
Sat Boju, Judetul Cluj

RUSSIA

KANT LTD
Electrolitny pr. d.7., k.2
115230 Moscow
T +7 495 604 1610
F +7 499 317 9806
www.kant.ru
v.siletskiy@kant.ru

SERBIA

PLANET BIKE CO. D.O.O.
Nova Mokroluska 5
11050 Beograd
T +381 37 42 0000
F +381 37 42 0011
www.planetbike.rs
sinisa.zivkovic@planetbike.rs

SLOVAKIA

INA SPORT SPOL. S R.O.
Hlavní 729/114
664 31 Lelekovice
T +421 905 669 710
www.inasport.sk
jan.devecka@inasport.sk

SLOVENIA

ELAN, D.O.O.
Begunje 1
4275 Begunje na Gorenjskem
T +386 4 53 51 429
F +386 4 53 51 444
www.ELANSkis.com
matic.rupar@ELAN.si

SPAIN

SUNSET
465 Route de la Dranse
74500 Amphion-Les-Bains
T +33 4 50 71 77 23
F +33 4 50 26 10 84
www.sunset-sport.fr
johann@sunset-sport.fr

SWEDEN

WÄNERSTEDT AB
Box 253 -
53323 Götene
T +46 511 51 788
F +46 511 34 03 10
andreas@wanerstedt.se

SWITZERLAND

ELAN SWITZERLAND GMBH
WIESENALSTRASSE 1
9445 REBSTEIN
T +41 79 569 28 20
www.elanskis.com
gerhard.haemmerle@elan-sport.ch

TURKEY

KAR SPOR
Kemankeş Karamustafa Paşa Mah.
Necatî Bey Cad. Gökçe Han No:16
Kat:7, Karaköy- Beyoğlu/ İstanbul
T 0212 243 27 89
F 0212 243 47 36
www.karspor.com.tr
bilgi@karspor.com

UKRAINE

XTREMA LINE P.E.
8-e Marta 19/17
88015 Uzhgorod
T +380 5037 22217
F +380 3122 30666
www.ELANsports.com.ua
ELANukraine@gmail.com

USA

ELAN USA CORP.
93 ETNA ROAD - LEBANON,
NH 03766
T +1 603 448 3101
F +1 603 448 1586
WWW.ELANSKIS.COM
INFO@ELANSKIS.COM

UZBEKISTAN

SPORT SHOP ADRENALIN
Mustaklik prospect 7 - Tashkent
T +998 97 7290682
sokolov_sale@mail.ru



ELAN is fully committed to a comprehensive environmental management system to minimize its impact on nature, as verified by the environmental standard ISO 14001.

ELAN, d. o. o., Begunje na Gorenjskem, Slovenia, December 2016. ELAN reserves the right to introduce modifications and changes without prior notice.